



POWERING INNOVATION THAT DRIVES HUMAN ADVANCEMENT

© 2025 ANSYS, Inc. or its affiliated companies  
Unauthorized use, distribution, or duplication is prohibited.

# Getting Started with Maxwell®: Designing a Rotational Actuator



ANSYS, Inc.  
Southpointe  
2600 Ansys Drive  
Canonsburg, PA 15317  
[ansysinfo@ansys.com](mailto:ansysinfo@ansys.com)  
<https://www.ansys.com>  
(T) 724-746-3304  
(F) 724-514-9494

Release 2025 R1  
January 2025

ANSYS, Inc. and  
ANSYS Europe,  
Ltd. are UL  
registered ISO  
9001:2015  
companies.

## Copyright and Trademark Information

© 1986-2025 ANSYS, Inc. Unauthorized use, distribution or duplication is prohibited.

ANSYS, Ansys Workbench, AUTODYN, CFX, FLUENT and any and all ANSYS, Inc. brand, product, service and feature names, logos and slogans are registered trademarks or trademarks of ANSYS, Inc. or its subsidiaries located in the United States or other countries. ICFEM CFD is a trademark used by ANSYS, Inc. under license. All other brand, product, service and feature names or trademarks are the property of their respective owners. FLEXlm and FLEXnet are trademarks of Flexera Software LLC.

## Disclaimer Notice

THIS ANSYS SOFTWARE PRODUCT AND PROGRAM DOCUMENTATION INCLUDE TRADE SECRETS AND ARE CONFIDENTIAL AND PROPRIETARY PRODUCTS OF ANSYS, INC., ITS SUBSIDIARIES, OR LICENSORS. The software products and documentation are furnished by ANSYS, Inc., its subsidiaries, or affiliates under a software license agreement that contains provisions concerning non-disclosure, copying, length and nature of use, compliance with exporting laws, warranties, disclaimers, limitations of liability, and remedies, and other provisions. The software products and documentation may be used, disclosed, transferred, or copied only in accordance with the terms and conditions of that software license agreement.

ANSYS, Inc. and ANSYS Europe, Ltd. are UL registered ISO 9001: 2015 companies.

## U.S. Government Rights

For U.S. Government users, except as specifically granted by the ANSYS, Inc. software license agreement, the use, duplication, or disclosure by the United States Government is subject to restrictions stated in the ANSYS, Inc. software license agreement and FAR 12.212 (for non-DOD licenses).

## Third-Party Software

See the legal information in the product help files for the complete Legal Notice for Ansys proprietary software and third-party software. If you are unable to access the Legal Notice, please contact ANSYS, Inc.

## Conventions Used in this Guide

Please take a moment to review how instructions and other useful information are presented in this documentation.

- Procedures are presented as numbered lists. A single bullet indicates that the procedure has only one step.
- Bold type is used for the following:
  - Keyboard entries that should be typed in their entirety exactly as shown. For example, “**copy file1**” means you must type the word **copy**, then type a space, and then type **file1**.
  - On-screen prompts and messages, names of options and text boxes, and menu commands. Menu commands are often separated by greater than signs (>). For example, “click **HFSS > Excitations > Assign > Wave Port.**”
  - Labeled keys on the computer keyboard. For example, “Press **Enter**” means to press the key labeled **Enter**.
- Italic type is used for the following:
  - Emphasis
  - Titles of publications
  - Keyboard entries when a name or a variable must be typed in place of the words in italics. For example, “**copy filename**” means you must type the word **copy**, then type a space, and then type the name of the file.
- The plus sign (+) is used between keyboard keys to indicate that you should press the keys at the same time. For example, “Press Shift+F1” means to press the **Shift** key and, while holding it down, press the **F1** key also. You should always depress the modifier key or keys first (for example, Shift, Ctrl, Alt, or Ctrl+Shift), continue to hold it/them down, and then press the last key in the instruction.

**Accessing Commands:** *Ribbons*, *menu bars*, and *shortcut menus* are three methods that can be used to see what commands are available in the application.

- The *Ribbon* occupies the rectangular area at the top of the application window and contains multiple tabs. Each tab has relevant commands that are organized, grouped, and labeled. An example of a typical user interaction is as follows:

"Click **Draw > Line**"

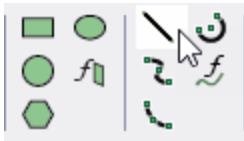

This instruction means that you should click the **Line** command on the **Draw** ribbon tab. An image of the command icon or a partial view of the ribbon is often included with the instruction.

- The *menu bar* (located above the ribbon) is a group of the main commands of an application arranged by category such File, Edit, View, Project, etc. An example of a typical user interaction is as follows:

"On the **File** menu, click the **Open Examples** command" means you can click the **File** menu and then click **Open Examples** to launch the dialog box.

- Another alternative is to use the *shortcut menu* that appears when you click the right-mouse button. An example of a typical user interaction is as follows:

"Right-click and select **Assign Excitation > Wave Port**" means when you click the right-mouse button with an object face selected, you can execute the excitation commands from the shortcut menu (and the corresponding sub-menus).

### Getting Help: Ansys Technical Support

For information about Ansys Technical Support, go to the Ansys corporate Support website, <http://www.ansys.com/Support>. You can also contact your Ansys account manager in order to obtain this information.

All Ansys software files are ASCII text and can be sent conveniently by e-mail. When reporting difficulties, it is extremely helpful to include very specific information about what steps were taken or what stages the simulation reached, including software files as applicable. This allows more rapid and effective debugging.

### Help Menu

To access help from the Help menu, click **Help** and select from the menu:

- **[product name] Help** - opens the contents of the help. This help includes the help for the product and its *Getting Started Guides*.
- **[product name] Scripting Help** - opens the contents of the *Scripting Guide*.
- **[product name] Getting Started Guides** - opens a topic that contains links to Getting Started Guides in the help system.

### Context-Sensitive Help

To access help from the user interface, press **F1**. The help specific to the active product (design type) opens.

You can press **F1** while the cursor is pointing at a menu command or while a particular dialog box or dialog box tab is open. In this case, the help page associated with the command or open dialog box is displayed automatically.

# Table of Contents

<b>Table of Contents</b> .....	<b>Contents-1</b>
<b>1 - Introduction</b> .....	<b>1-1</b>
The Maxwell Desktop .....	1-2
<b>2 - Setting Up the Design</b> .....	<b>2-1</b>
Open Maxwell and Save a New Project .....	2-1
Specify a Solution Type .....	2-2
Set the Drawing Units .....	2-2
<b>3 - Creating the Geometric Model</b> .....	<b>3-1</b>
Set the Drawing Plane and Movement Mode .....	3-1
Create the Outer Armature Object .....	3-2
Draw the Outer Cylinder .....	3-2
View the Entire Cylinder .....	3-3
Draw the Inner Cylinder .....	3-4
Subtract the Cylinders .....	3-5
Add the Poles to the Outer Armature .....	3-5
Move the Box into a Pole Position .....	3-5
Create a Duplicate of the Pole Box .....	3-6
Unite the Outer Armature and Magnetic Pole Boxes .....	3-6
Finalize the Outer Armature Magnetic Pole Faces .....	3-7
Create the Inner Armature Object .....	3-8
Draw the Inner Armature Cylinders .....	3-8
Add the Poles to the Inner Armature .....	3-10
Create Box for Inner Armature Magnetic Poles: .....	3-11
Move the Box into Position .....	3-11
Create a Duplicate of the Box .....	3-11
Unite the Inner Armature and Magnetic Pole Boxes .....	3-11

Finalize the Inner Armature Magnetic Pole Faces .....	3-11
Create the Coils .....	3-13
Create the New Coordinate System .....	3-13
Sweep a Cross-Section across a New Path .....	3-14
Draw the Sweep Path in the XZ Plane .....	3-14
Draw the Cross-Section of the Coil in the YZ Plane .....	3-14
Sweep the Cross-Section Along the Path .....	3-15
Set the Drawing Plane Back to XZ .....	3-16
Intersect the Coil Shape with a Cylinder .....	3-16
Move the Coil into the Final Position .....	3-16
Create a Mirror Duplicate of the Coil .....	3-16
Create the Coil Terminals .....	3-17
Create the Background (Region) .....	3-18
Parameterize the Model .....	3-19
<b>4 - Defining Material Properties .....</b>	<b>4-1</b>
Define the Nonlinear Material for Armatures .....	4-1
Assign Material Properties for Other Objects .....	4-3
<b>5 - Setting Up and Running the Analysis .....</b>	<b>5-1</b>
Assign Excitations .....	5-1
Set Up Parameter Calculations .....	5-1
Set Up the Torque Calculation .....	5-1
Set Up the Inductance Matrix Calculation .....	5-2
Exploring the Matrix Setup Grouping Functionality .....	5-2
Example 1: Series/Parallel .....	5-3
Example 2: Series/Parallel .....	5-3
Set Up the Analysis .....	5-3
Validate Design .....	5-4
Run the Analysis .....	5-4

<b>6 - Postprocessing the Results</b> .....	<b>6-1</b>
Plot the Magnetic Flux Density Vector .....	6-1
Create an Object List .....	6-1
Plot the Quantity .....	6-1
Plot the Magnetic Flux Density Magnitude .....	6-2
<b>7 - Running a Parametric Analysis</b> .....	<b>7-1</b>
Create a Parametric Analysis Report .....	7-2
Create an Animation Using Saved Parametric Field Data .....	7-3
<b>8 - Close the Project and Exit Electronics Desktop</b> .....	<b>8-1</b>
<b>Index</b> .....	<b>Index-1</b>



# 1 - Introduction

This Getting Started Guide is written for Maxwell beginners and for experienced users who would like to quickly re-familiarize themselves with the capabilities of Maxwell. This guide leads you step-by-step through creating, solving, and analyzing the results of solving a rotational actuator magnetostatic problem.

By following the steps in this guide, you will learn how to perform the following tasks:

- Draw a geometric model
- Modify a model's design parameters
- Assign variables to a model's design parameters
- Specify solution settings for a design
- Validate a design's setup
- Run a Maxwell simulation
- Plot the magnetic flux density vector
- Run a parametric analysis
- Create an animation using saved parametric field data

**Note:** This guide is designed to help you build and simulate a rotational actuator in Ansys Maxwell. If you would like to skip the model creation process or need help trouble shooting the model you created, a prebuilt version rotational actuator is located in \\AnsysEM\VersionNumber\OS\Examples\Maxwell\Actuators.

## Maxwell Solution Types

Ansys Maxwell is an interactive software package that uses finite element analysis (FEA) to simulate (solve) electromagnetic field problems. Maxwell integrates with other Ansys software packages to perform complex tasks while remaining simple to use. Maxwell incorporates both a set of 2D solvers and 3D solvers in an integrated user interface. This guide will focus on 3D capabilities. 2D problems examples are cover in a separate 2D Getting Started Guide.

The following types of stand-alone solutions are supported by Maxwell 3D:

- **Magnetostatic linear and nonlinear 3D fields** caused by a user-specified distribution of DC current density and permanent or externally applied magnetic fields. Materials can be nonlinear and anisotropic. Additional quantities that can be computed include torque, force, and self and mutual inductances.
- **Harmonic (sinusoidal variation in time) steady-state magnetic fields** with pulsation-induced eddy currents in massive solid conductors caused by one of the following:
  - A user-specified distribution of AC currents (all with the same frequency but with possibly different initial phase angles).

- Externally applied magnetic fields.

This solution includes displacement currents for calculating near field electromagnetic wave radiation.

- **Transient (time domain) magnetic fields** caused by permanent magnets, conductors, and windings supplied by voltage and/or current sources with arbitrary variation as functions of time. Rotational or translational motion effects can be included in the simulation. This option uses the TAU solver.
- **A-Phi Formulation:** This solver is an alternative to the transient TAU solver.  $A$  is the Magnetic Vector Potential and  $\phi$ (Phi) is the Electric Scalar Potential. The A-Phi solver allows multi-terminal conductors, and it supports sources of various types on a single conduction path; the J and E fields are calculated directly because it is a first-order approximation. This option is useful for application fields in Power Electronics, Bus Bars, PCBA, *etc.*, where the voltage distribution in multiple conductors is essential.
- **Electrostatic 3D fields** caused by a user-specified distribution of voltages and charges in non-conducting regions. Additional quantities that can be computed include torque, force, and capacitances.
- **Electric DC Conduction 3D fields** in conductors characterized by a spatial distribution of voltage, electric field, and current density. Power loss can also be computed. In addition, optional simulation of fields in insulating materials is supported.
- **Transient (time domain) 3D Electric fields** caused by time dependent voltage, current and charge distributions. All sources are arbitrary functions of time.
- **AC Conduction** 3D electric fields and losses arising in conductors and imperfect (lossy) dielectrics from the application of an alternating (AC) voltage or external current to the electrodes. The AC conduction field solver assumes that all sources are sinusoids oscillating at the same frequency.

In addition, Maxwell may be coupled with other simulators to provide a greater range of solution capability. Couplings to Workbench for stress analysis, HFSS for ferrite analysis, Fluent for thermal analysis, and Twin Builder for Finite Element/Circuit co-simulation are all supported.

## The Maxwell Desktop

The following graphic shows the different sections of the Maxwell desktop:

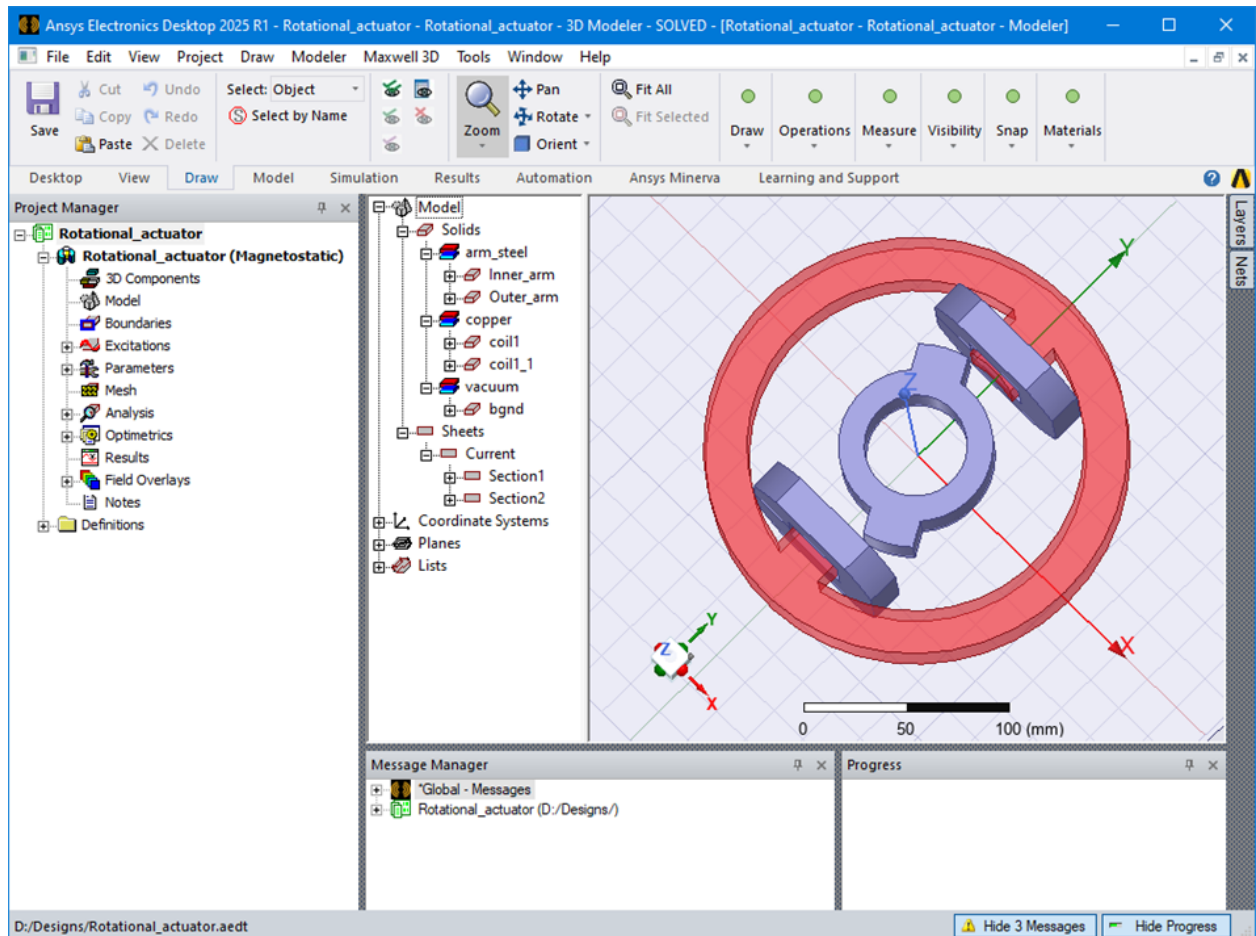

## General Procedure for Setting Up Maxwell Designs

You are not required to follow a specific order when setting up your Maxwell design. However, the following order is recommended, particularly for new users:

1. Open Ansys Electronics Desktop by double-clicking the desktop icon or by clicking **Start** > **Programs** > **Ansys EM Suite** [version] > **Ansys Electronics Desktop** [version] from the Windows taskbar.
2. Add a Maxwell 3D design and save the new project.
3. Draw the geometry of the model.
4. Optionally, modify the model's design parameters.
5. Assign variables to design parameters.
6. Assign excitations and boundary conditions.
7. Specify solution settings.
8. Run a Maxwell simulation.
9. Create postprocessing plots.

10. Create a parametric analysis.
11. Create a field animation of the parametric analysis results.

### About the Example Design

The application described in this Getting Started guide is an extension of the *TEAM Workshop Problem 24* rotational actuator design. The geometry is shown below:

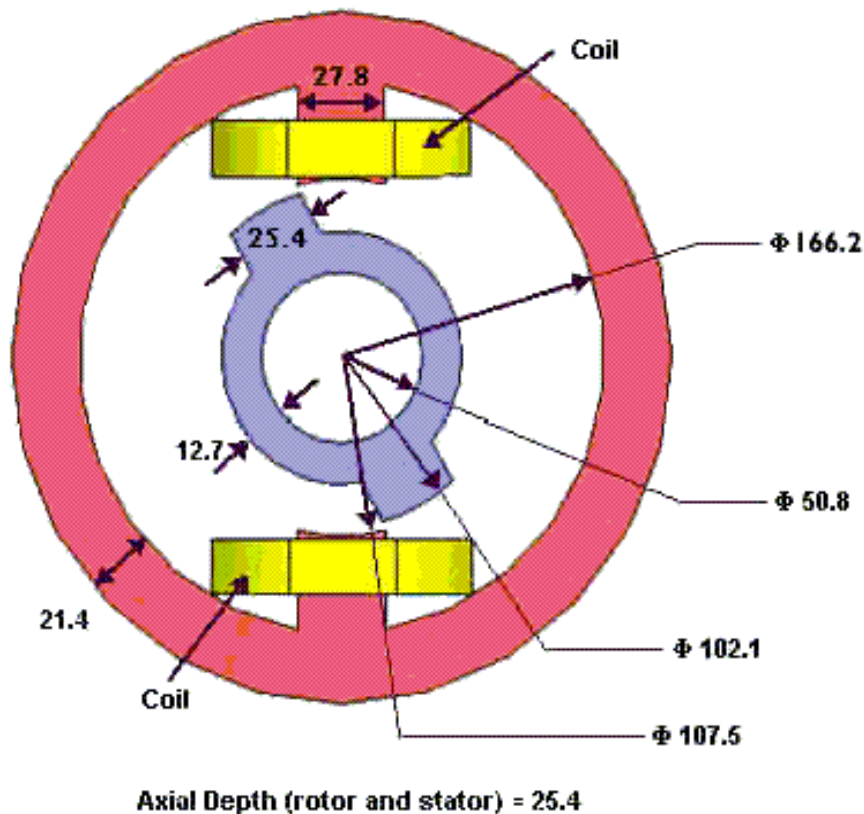

The outer part is a ferromagnetic nonlinear armature carrying two coils. The inner part is made of the same nonlinear material and can rotate around an axis. The inner and outer parts of the device are coaxial.

The field distribution will likely cause the flux density to concentrate in the two steel armatures in the regions where the distance between them is minimal. The expected edge effect will then further increase the field concentration.

In this example, we will compute the torque acting on the inner armature and the flux linkage of the two coils. For a presentation of the results and the corresponding FEM code, see the *IEEE Transactions on Magnetics, Vol 38, No. 2, March 2002, pp 609-612*.

## 2 - Setting Up the Design

In this chapter, you will complete the following tasks:

- Open and save a new project.
- Insert a new Maxwell design into the project.
- Select a solution type for the project.
- Set the drawing units for the design.

### Open Maxwell and Save a New Project

A project is a collection of one or more designs that is saved in a single \*.aedt file. A new project is automatically created when Ansys Electronics Desktop is launched.

To open Ansys Electronics Desktop, add a new Maxwell 3D design, and save the default project with a new name:

1. Double-click the **Ansys Electronics Desktop** icon on your desktop to launch Ansys Electronics Desktop.
  - You can also start Ansys Electronics Desktop by clicking **Start > Programs > Ansys EM Suite [version] > Ansys Electronics Desktop [version]** from Windows.

2. Click **Project > Insert Maxwell 3D Design**.

The new design is listed in the Project Manager tree. By default, it is named **Maxwell3DDesign1**. The **Modeler** window appears to the right of the Project Manager window.

3. Click **File > Save As**.

The **Save As** dialog box appears.

4. Locate and select the folder in which you want to save the project.
5. Type **Rotational\_actuator** in the **File name** box, and click **Save**.

The project is saved in the specified folder under the name **Rotational\_actuator.aedt**.

6. Rename the design:

- a. Right-click **Maxwell3DDesign1**.

A shortcut menu appears.

- b. Select **Rename**.

The design name becomes highlighted and editable.

- c. Type **Rotational\_actuator** as the name for the design, and press **Enter**.

The project and design are now both named **Rotational\_actuator**.

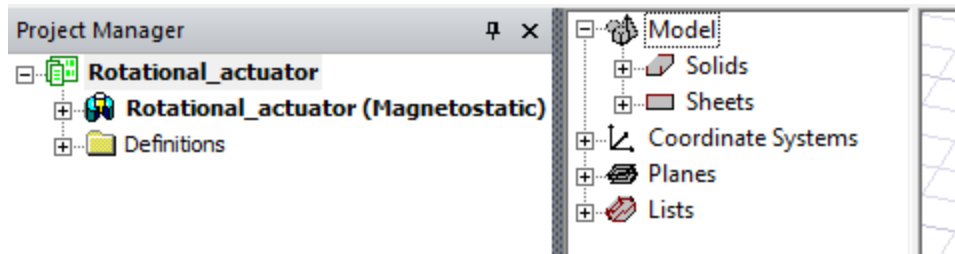

## Specify a Solution Type

As mentioned in the introduction, multiple solution types are available, depending on the specific application. For this design, choose a **Magnetostatic** solution.

1. Click **Maxwell 3D > Solution Type** from the menus.

The **Solution Type** dialog box appears.

2. Select the **Magnetostatic** radio button.
3. Click **OK**.

## Set the Drawing Units

1. Click **Modeler > Units**.

The **Set Model Units and Max Extent** dialog box appears.

2. Select **mm** from the **Select units** drop-down menu.
3. Click **OK**.

## 3 - Creating the Geometric Model

In this chapter you will complete the following tasks:

- Set the drawing plane and movement mode
- Create the outer armature of the actuator by subtracting and uniting objects
- Create the inner armature of the actuator
- Create the coils
- Create the coil terminals
- Create the background object
- Finalize the geometry by rotating the inner arm

### Set the Drawing Plane and Movement Mode

Before creating the geometry, make sure the **XY** drawing plane is selected and **3D** is selected as the movement mode.

1. Click on the **Draw** tab.
2. From the Grid menu, select **XY** for the Drawing plane.
3. Select **3D** for the **Movement mode**.

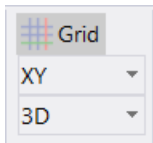

**Note:** If you have adjusted the size of the Ansys Electronic Desktop window to make it smaller, the **Grid** menu may not be visible. In that case, it is available from the **Visibility** drop-down menu, which appears when the Ansys Electronic Desktop window has been made smaller.

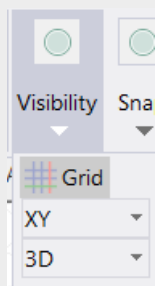

## Create the Outer Armature Object

The outer armature consists of two cylinders (for an outer and inner radius) that are subtracted to leave the armature. Magnetic poles are then added to the armature object.

### Draw the Outer Cylinder

Create the outer radius of the outer armature object.

To create the outer cylinder:

1. Click **Draw > Cylinder**.

The cursor changes to a small black box, indicating that you are in **Drawing** mode.

2. Select the center of the cylinder by clicking at the **(0,0,0)** location, which is the origin for the coordinate system, and press the **Tab** key to jump to the manual entry area in the Status Bar at the bottom of the screen.
3. Notice the Status Bar is prompting for Radius of the cylinder. Type **104.5** for the radius in the **dX** box, and ensure that **dY** and **dZ** are set to **zero**. Press **Enter**.
4. The Status Bar is now prompting for height of the cylinder. Type **25.4** for the height in the **dZ** box, and press **Enter**. The cylinder is created and the default properties appear in the **Properties Window**.

**Note:** If the Properties window is not visible, from the menu bar, select **View > Properties**. You can also open the Properties window by double-clicking an entry in the history tree. This example assumes that the Properties window is always open.

5. In the **Attribute** tab, change the **Name** (currently **Cylinder1**) to **Outer\_arm**.
6. Change the color of the cylinder to **red**:
  - a. In the **Color** row, click the **Edit** button.  
The **Color** palette dialog box appears.
  - b. Select any of the red shades from the **Basic colors** group, and click **OK** to return to the **Properties** window.
7. Set the transparency to **0.6**:
  - a. Click the button for the **Transparent** property.  
The **Set Transparency** dialog box appears.
  - b. Type **0.6** in the text box, and click **OK** to return to the **Properties** window.

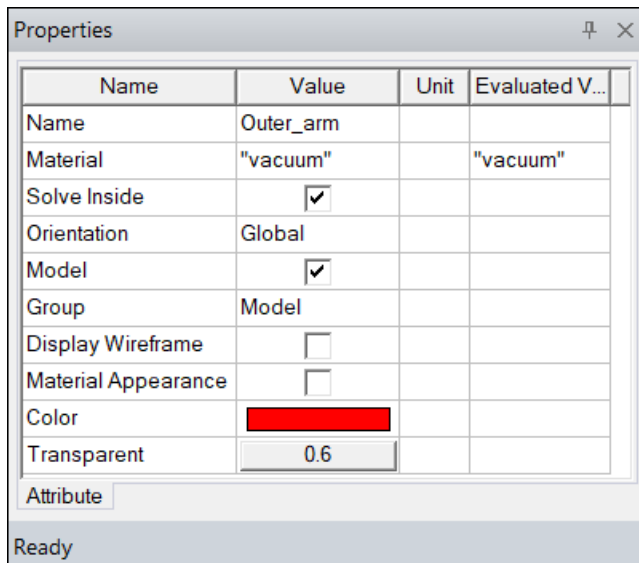

**Note:** To view and edit geometric data, double-click the CreateCylinder entry in the **Model** history tree window to open the **Command** tab.

8. If you are using the pop-up **Properties** dialog box, click **OK** to close the **Properties** window. A cylinder named **Outer\_arm** is drawn.

## View the Entire Cylinder

It is easier to view the model you are drawing if you set it to fit the screen.

To fit the entire model on the screen:

- Click **View > Fit All > All Views**; or use the keyboard shortcut **Ctrl+D**.

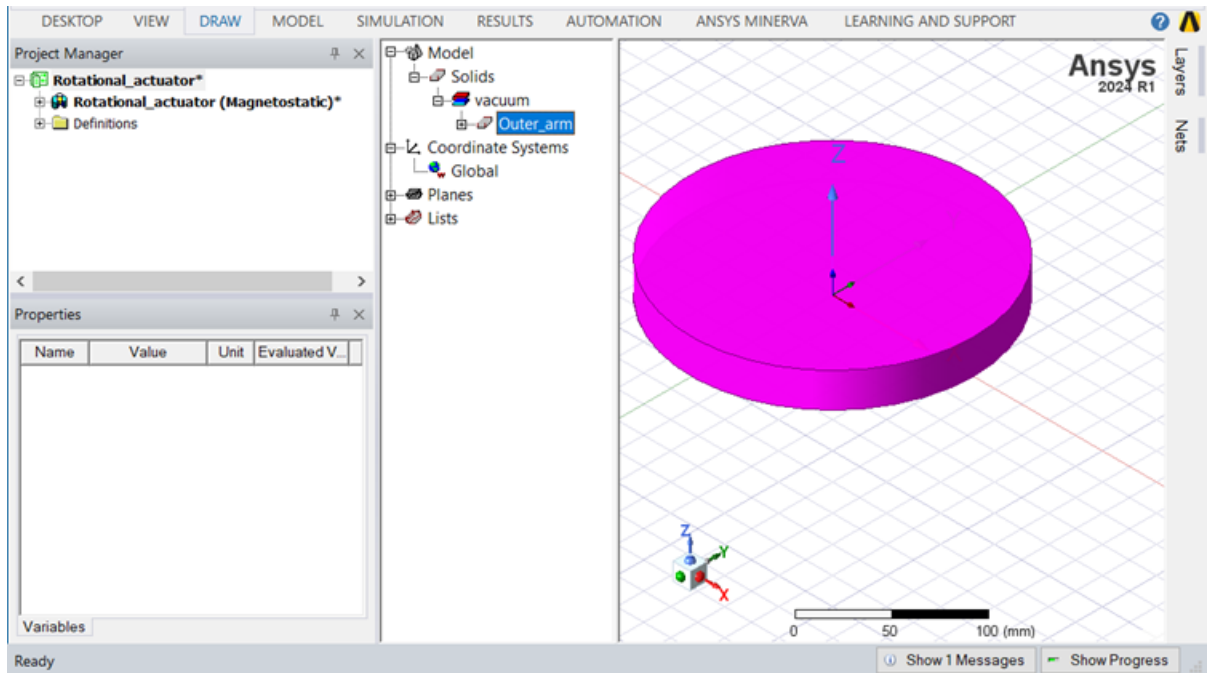

## Draw the Inner Cylinder

Add the inner radius for the outer armature object.

To create the inner cylinder:

1. Click **Draw > Cylinder**.

The cursor changes to a small black box, indicating that you are in **Drawing** mode.

2. Select the center of the cylinder by clicking at the **(0,0,0)** location, which is the origin for the coordinate system. Press **Tab** to navigate to the keyboard entry area on the Status Bar.
3. Type **83.1** for the radius in the **dX** box at the bottom of the screen, and press **Enter**.

**Note:** Use the Tab key to navigate between value fields (from X to Y to Z and from dX to dY to dZ).

4. Type **25.4** for the height in the **dZ** box, and press **Enter**.

The **Properties** window appears.

5. Click the **Attribute** tab.
6. Change the **Name** to **Cylinder\_tool**.

## Subtract the Cylinders

Subtract **Cylinder\_tool** from **Outer\_arm**.

To subtract the second cylinder from the first:

1. In the history tree, expand the **Model\Solids** entry, and select the **Outer\_arm** cylinder, press and hold down **Ctrl**, and select the **Cylinder\_tool** cylinder.
2. Click **Modeler > Boolean > Subtract**.

The **Subtract** dialog box appears.

**Note:** The first object selected appears under **Blank Parts**, and the second object selected appears under **Tool Parts**. Tool parts are removed during a Boolean operation (unless cloned) and the final part takes on the name and other characteristics of the Blank Part.

3. If necessary, move the **Outer\_arm** object to the **Blank Parts** list and the **Cylinder\_tool** object to the **Tool Parts** list. To move an object from one list to another, select it, and click the appropriate arrow.
4. Click **OK**.

## Add the Poles to the Outer Armature

Add two magnetic poles to the outer armature. To do so, you need to create a box, move the box into the position for the poles, and use the **Mirror** command to create a duplicate of the box. Then unite the three model objects, and subtract a newly created cylinder to arrive at the final shape.

To create the box for the outer armature magnetic poles:

1. Click **Draw > Box**.
2. Type the box position (**-13.9, 0, 0**) in the **X**, **Y**, and **Z** fields at the bottom of the screen, and then press **Enter**.
3. Type the box size (**27.8, -40, 25.4**) in the **dX**, **dY**, **dZ** fields, and then press **Enter**.

A box named **Box1** is drawn.

## Move the Box into a Pole Position

To move the box into the correct position for one of the magnetic poles:

1. Select **Box1** from the **Model\Solids** entry in the history tree.
2. Click **Edit > Arrange > Move**.
3. Type (**0, 0, 0**) in the (**X, Y, Z**) fields as the origin of the move vector and press **Enter**.

4. Type **(0, -45, 0)** in the **(dX, dY, dZ)** fields as the target point of the move vector and press **Enter**.

## Create a Duplicate of the Pole Box

To create a duplicate of the box using mirroring:

1. Select **Box1** from the history tree.
2. Click **Edit > Duplicate > Mirror**.
3. Type **(0, 0, 0)** in the **(X, Y, Z)** fields as coordinates for the anchor point on the mirror plane, and press **Enter**.
4. Type **(0, 1, 0)** in the **(dX, dY, dZ)** fields as coordinates of target point of the vector normal to the mirror plane, and press **Enter**.

A second box, named **Box1\_1**, is drawn.

## Unite the Outer Armature and Magnetic Pole Boxes

To unite the three objects in the model:

1. In the history tree window, select **Outer\_arm**, hold down the **Ctrl** key, and then select **Box1** and **Box1\_1**.
2. Select **Modeler > Boolean > Unite**.  
The first selected object was **Outer\_arm**; therefore, the default name for the final object is **Outer\_arm**.

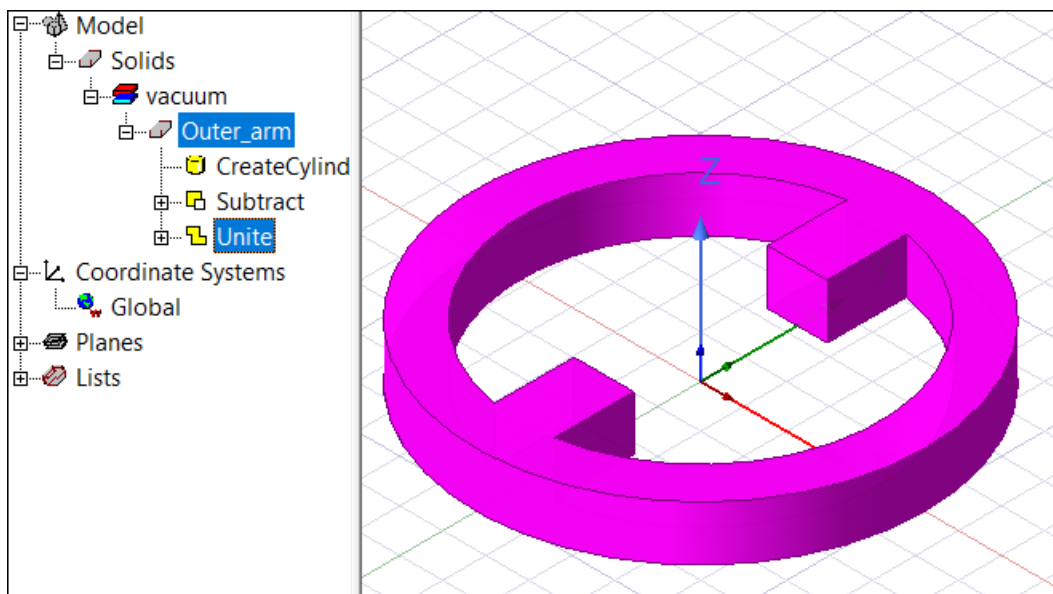

## Finalize the Outer Armature Magnetic Pole Faces

To provide the final shape for the magnetic pole faces:

1. Create a cylinder with the center at **(0, 0,0)**, a radius of **53.75**, and a height of **25.4**:
  - a. Click **Draw > Cylinder**.

The cursor changes to a small black box, indicating that you are in **Drawing** mode.
  - b. Select the center of the cylinder by clicking at the **(0,0,0)** location, which is the origin for the coordinate system. **Tab** to the keyboard entry area.
  - c. Type **53.75** for the radius in the **dX** box at the bottom of the screen and press **Enter**.
  - d. Type **25.4** for the height in the **dZ** box and press **Enter**.

The **Properties** window contains the properties of the new cylinder, **Cylinder1**.

2. Because we will be using a similar cylinder in the next section, we will make a copy of **Cylinder1** for later use.
  - a. Select **Cylinder1**.
  - b. Click **Edit > Copy** to create a copy of the object on the clipboard.
  - c. Next select **Edit > Paste** to paste a new copy, named **Cylinder2** in the **Model** history tree, into the project at the same location as the original.
  - d. Right-click **Cylinder2** in the history tree, and select **View > Hide in Active View**.
3. Subtract **Cylinder1** from **Outer\_arm** to achieve the curved edges on the poles:
  - a. Select the **Outer\_arm** object, press and hold the **Ctrl** key, and then select **Cylinder1**.
  - b. Select **Modeler > Boolean > Subtract**.

The **Subtract** dialog box appears.

**Note:** Pressing **F1** with any dialog on the screen will open the Context-Sensitive Help system to the appropriate page for that dialog.

- c. Make sure the **Outer\_arm** object is in the **Blank Parts** list and the **Cylinder1** object is in the **Tool Parts** list.
- d. Click **OK**.

The **Outer\_arm** object should look as shown in the following graphic:

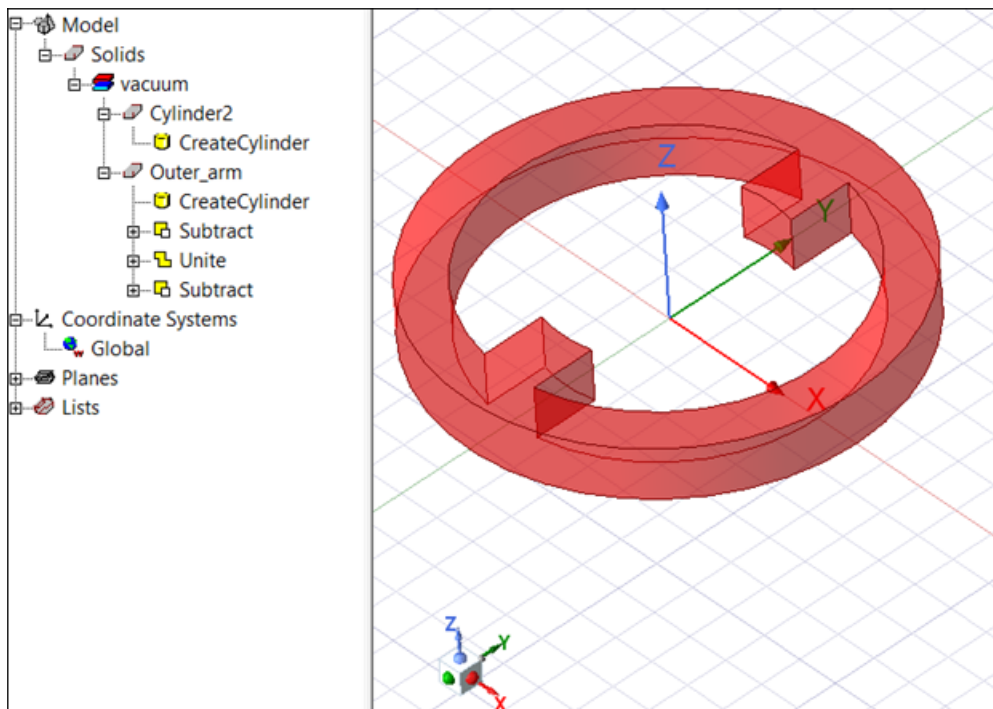

4. Click **File > Save** to save all of the operations up to this point.

## Create the Inner Armature Object

The inner armature consists of two cylinders (for an outer and inner radius) that are subtracted to leave the armature. Magnetic poles are then added to the armature object. This topic covers how to

- [Draw the Inner Armature Cylinders](#)
- [Add the Poles to the Inner Armature](#)

## Draw the Inner Armature Cylinders

To draw the inner armature:

1. Create a cylinder called **Shaft** with the following properties.

Property	Value
Center	(0, 0, 0)
Radius (dX)	25.4 mm
Height	25.4 mm

**Property Value**  
(dZ)

Step-by-step instructions if needed:

- a. Click **Draw > Cylinder**.
- b. Select the center of the cylinder by clicking at the **(0,0,0)** location, which is the origin for the coordinate system. **Tab** to the keyboard entry area on the Status Bar.
- c. Type **25.4** for the radius in the **dX** box at the bottom of the screen, and press **Enter**.
- d. Type **25.4** for the height in the **dZ** box, and click **Enter**.

The **Properties** window appears.

- e. Click the **Attribute** tab.
  - f. Change the **Name** to **Shaft**.
  - g. Click **OK**.
- A cylinder named **Shaft** is drawn.

2. The properties of **Cylinder2** can be modified to create the outer radius of the inner armature to eliminate the need to draw another object.
  - a. In the history tree, right-click **Cylinder2** and select **View > Show in Active View**.
  - b. Select the CreateCylinder entry in the history tree under the **Cylinder2** object.

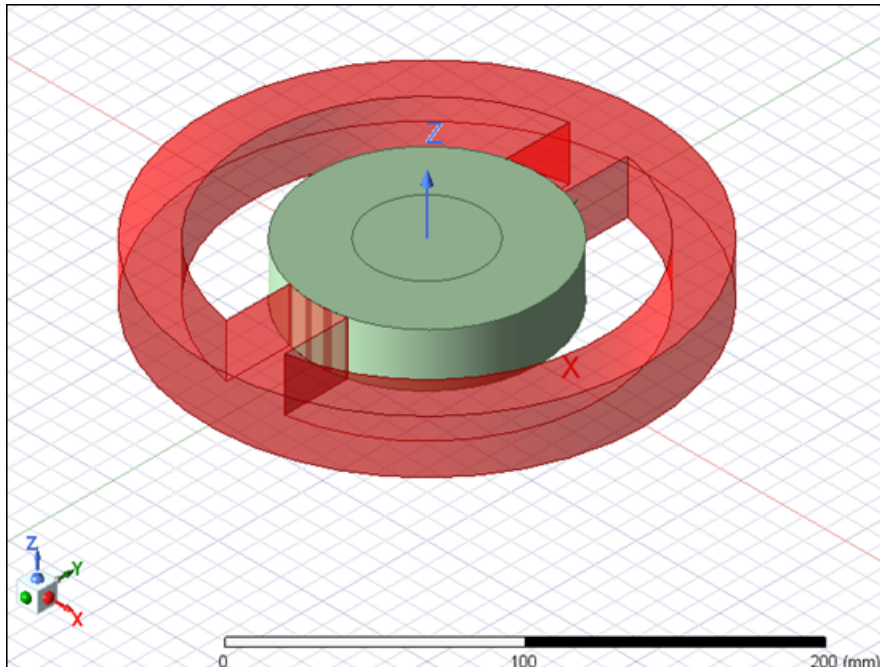

- c. In the **Properties Window**, select the **Command** tab.

- d. Select the value field containing **53.75** corresponding to **Radius**. The field becomes highlighted and editable.
- e. Change the value to **38.1** and press **Enter**. The radius of **Cylinder2** is changed in the modeler window.
- f. In the history tree, select **cylinder2**. The **Attribute** tab is now visible in the **Properties Window**.
- g. Change the name of the object by selecting **Cylinder2** in the value field corresponding to **Name** and entering **Inner\_arm**. Press **Enter**.
- h. Subtract **Shaft** from **Inner\_arm**:
  - i. Select **Inner\_arm**, press and hold down the **Ctrl** key, and select **shaft**.
  - ii. Select **Modeler > Boolean > Subtract** from the menu bar. The **Subtract** dialog box appears.
  - iii. Make sure **Inner\_arm** is in the **Blank Parts** list and **shaft** is in the **Tool Parts** list.
  - iv. Click **OK**.

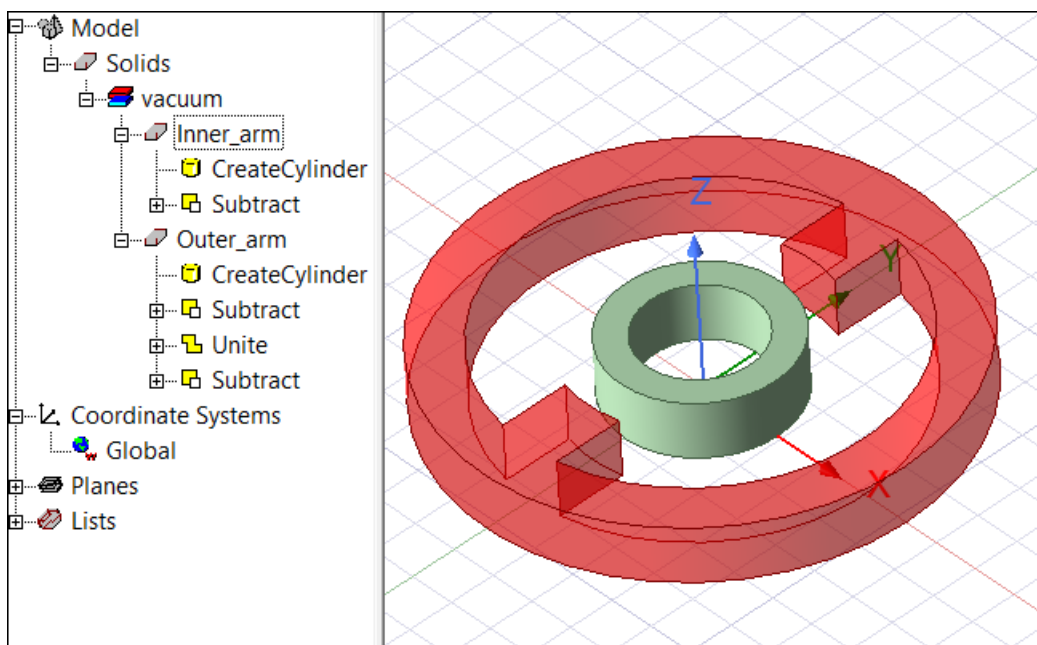

## Add the Poles to the Inner Armature

To create two magnetic poles for the inner armature, you need to create another box, move the box into the correct position, and use the **Mirror** command to create a duplicate of the box. Unite the inner armature with the two boxes, and intersect it with a cylinder to arrive at the final shape.

## Create Box for Inner Armature Magnetic Poles:

1. Click **Draw > Box**.
2. Type the box position (**-12.7, 0, 0**) in the **X, Y, and Z** fields at the bottom of the screen, and then press **Enter**.
3. Type the box size (**25.4, -20, 25.4**) in the **dX, dY, dZ** fields, and then press **Enter**.

A box named **Box2** is drawn.

## Move the Box into Position

1. Select **Box2** in the history tree.
2. Select **Edit > Arrange > Move**.
3. Type (**0, 0, 0**) in the (**X, Y, Z**) fields as the origin of the move vector, and press **Enter**.
4. Type (**0, -35, 0**) in the (**dX, dY, dZ**) fields as the target point of the move vector, and press **Enter**.

## Create a Duplicate of the Box

1. Select **Box2** in the history tree.
2. Select **Edit > Duplicate > Mirror**.
3. Type (**0, 0, 0**) in the (**X, Y, Z**) fields as coordinates for the anchor point on the mirror plane, and press **Enter**.
4. Type (**0, 1, 0**) in the (**dX, dY, dZ**) fields as coordinates of target point of the vector normal to the mirror plane, and press **Enter**.

A box named **Box2\_1** is drawn.

## Unite the Inner Armature and Magnetic Pole Boxes

1. In the history tree, select **Inner\_arm**, press and hold down the **Ctrl** key, and then select **Box2** and **Box2\_1**.
2. Select **Modeler > Boolean > Unite**.

Because the first selected object was **Inner\_arm**, the final object name is **Inner\_arm**. The name of the objects can be changed in the **Properties** window on the **Attribute** tab.

## Finalize the Inner Armature Magnetic Pole Faces

To provide the final shape for the magnetic pole faces:

1. Create a cylinder with the center at (**0, 0,0**), a radius of **51.05**, and a height of **25.4**:
  - a. Click **Draw > Cylinder**.

The cursor changes to a small black box, indicating that you are in **Drawing** mode.

- b. Select the center of the cylinder by clicking at the **(0,0,0)** location, which is the origin for the coordinate system.
- c. Type **51.05** for the radius in the **dX** box at the bottom of the screen, and press **Enter**.
- d. Type **25.4** for the height in the **dZ** box and press **Enter**.

The **Properties** window appears.

- e. Click the **Attribute** tab.
- f. Change the **Name** to **Finalpole2**.
- g. Click **OK**.

A cylinder called **Finalpole2** is drawn.

2. Intersect **Inner\_arm** and the new **Finalpole2** object:
  - a. In the history tree, select the **Inner\_arm** object, press and hold down the **Ctrl** key, and then select **Finalpole2**.
  - b. Select **Modeler > Boolean > Intersect**.
3. Rotate the **Inner\_arm** object by 29 degrees:
  - a. In the history tree, right-click **Inner\_arm**, and select **Edit > Arrange > Rotate**.
  - b. In the Rotate dialog box that opens, select the **Z** axis.
  - c. For the Angle, enter **29 deg**, then click **OK**.

The final armatures should look like the following:

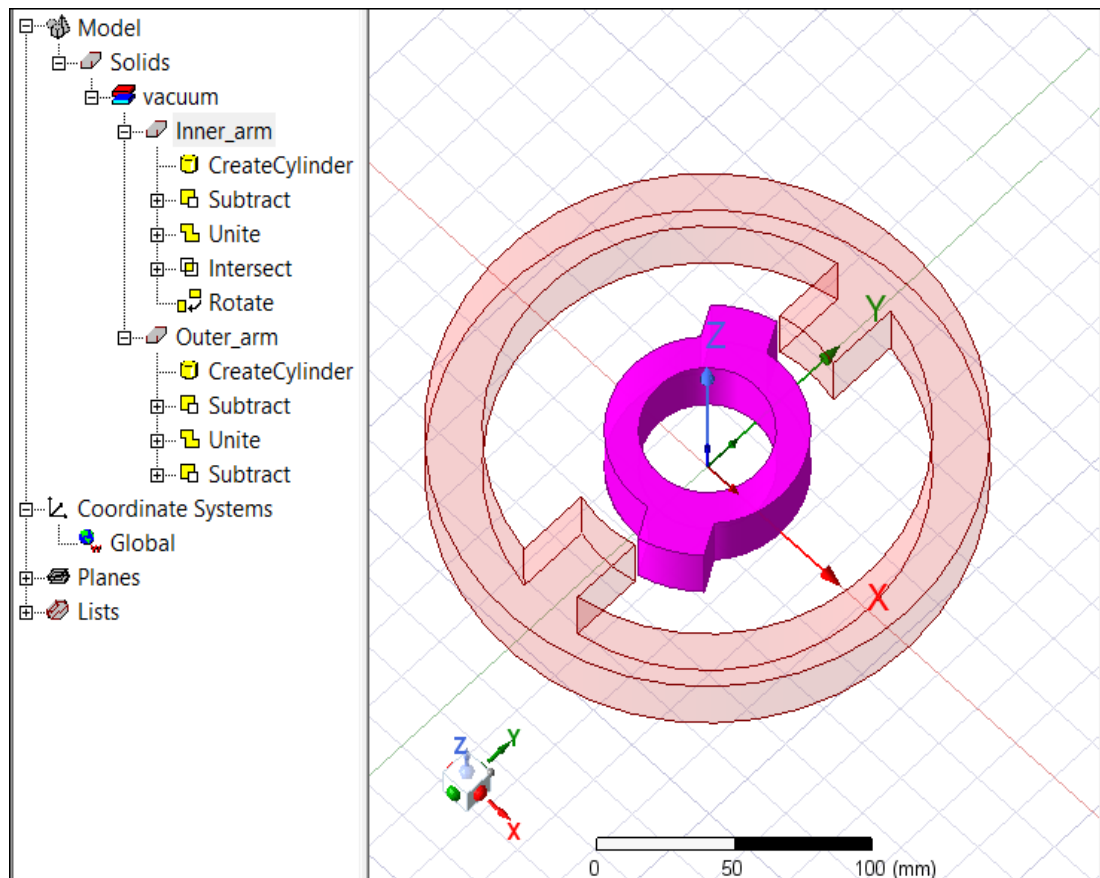

4. Click **File > Save** to save all of the operations up to this point.

## Create the Coils

In this topic, you will learn how to create the coils of the actuator. To create the coils, do the following:

- Create a new coordinate system (RelativeCS1) so that in the new coordinate system, the XY plane becomes the median plane of the model.
- Create a cross-section of the coils and [sweep it across a path](#) that will create the 3D coils.
- Intersect the coil shape with a cylinder .
- Create a duplicate to achieve the final coil shape.

## Create the New Coordinate System

1. Select **Modeler > Coordinate System > Create > Relative CS > Offset**.
2. Press the **Tab** key to switch to the keyboard entry area of the Status Bar.

3. Type the new origin (**0, 0, 12.7**) in the (**X, Y, Z**) boxes and then press **Enter**.

The new coordinate system is created and named **RelativeCS1**.

## Sweep a Cross-Section across a New Path

The coil(s) are created by sweeping the coil cross-section along a path as follows:

- [Set the Drawing Plane to ZX](#)
- [Draw the Sweep Path](#)
- [Set the Drawing Plane to YZ](#)
- [Draw the Cross-Section of the Coil](#)
- [Sweep the Cross-Section Along the Path](#)
- [Set the Drawing Plane Back to ZX](#)

### Draw the Sweep Path in the XZ Plane

To create the path you want to use as the sweep path:

1. Select **Modeler > Grid Plane > XZ**.
2. Click **Draw > Rectangle**.
3. **Tab** to the keyboard entry area and type (**-17, 0, -15.5**) in the (**X, Y, Z**) boxes, for the rectangle position, and then press **Enter**.
4. Type (**34, 0, 31**) in the (**dX, dY, dZ**) boxes, for the rectangle dimensions, and press **Enter**.

The **Properties** window appears.

5. Click the **Attribute** tab.
6. Change the **Name** to **Path**, and press **Enter**.
7. Click **OK**.

A rectangle named **Path** is drawn.

8. Uncover the faces:
  - a. Click **Edit > Selection Mode > Faces**, and select **path** by clicking on it in the **Modeler** window.
  - b. Click **Modeler > Surface > Uncover Faces**.

### Draw the Cross-Section of the Coil in the YZ Plane

To draw the cross-section of the coil:

1. Select **Modeler > Grid Plane > YZ**.
2. Click **Draw > Rectangle** to draw the cross-section of the coil.
3. Type (**0, 0, 15.5**) in the (**X, Y, Z**) boxes, for the rectangle position, and then press **Enter**.

4. Type **(0, 17, 24)** in the **(dX, dY, dZ)** boxes, for the rectangle dimensions, and press **Enter**.

The **Properties** window appears.

5. In the **Properties** window, click the **Attribute** tab.
6. Change the **Name** to **Coil1**, then press **Enter**.

A rectangle named **Coil1** is drawn.

## Sweep the Cross-Section Along the Path

To sweep the cross-section (**Coil1**) along the path (**Path**) to create the coil:

1. In the history tree, select **Path**, press and hold down the **Ctrl** key, and then select **Coil1**.
2. Click **Draw > Sweep > Along Path**.

The **Sweep along path** dialog box appears.

3. Click **OK** to accept the defaults.

The **Properties** window appears.

4. Click **OK** to create the coil. The coil retains the name **Coil1** from the cross-section used to create it.

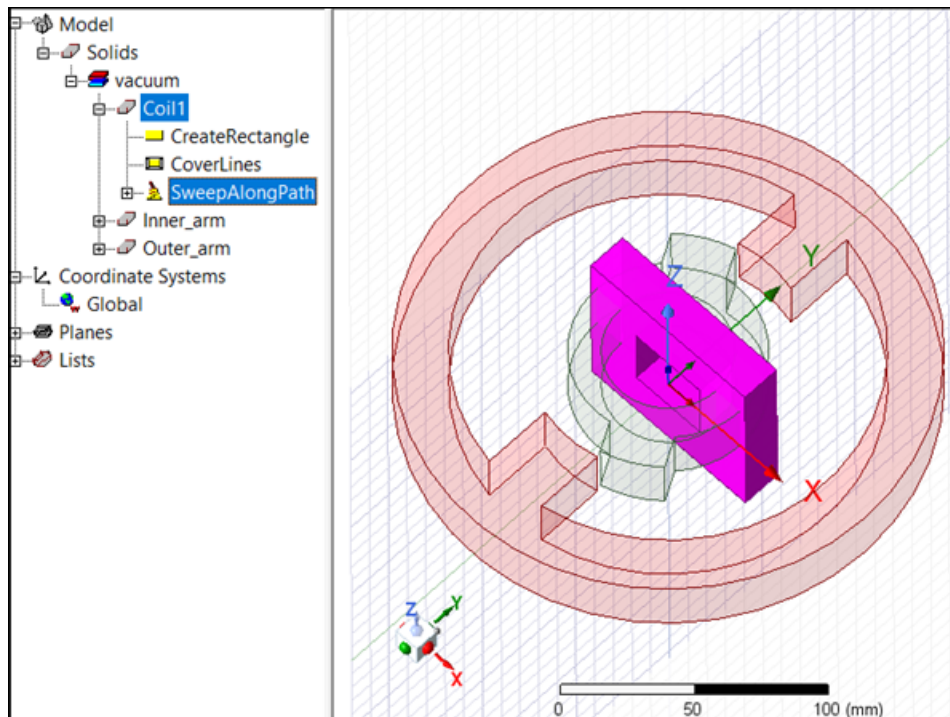

## Set the Drawing Plane Back to XZ

To set the drawing plane:

- Select **Modeler > Grid Plane > XZ**.

## Intersect the Coil Shape with a Cylinder

1. Create a cylinder at the origin with a radius (**dZ**) of **43** mm and a height (**dY**) of **17** mm:

- a. Click **Draw > Cylinder**.

The cursor changes to a small black box, indicating that you are in **Drawing** mode.

- b. Select the center of the cylinder by clicking at the **(0,0,0)** location, which is the origin for the coordinate system.
- c. Type **43** for the radius in the **dZ** box at the bottom of the screen, and press **Enter**.
- d. Type **17** for the height in the **dY** box, and press **Enter**.
- e. In the Properties window, click the **Attribute** tab.
- f. Change the **Name** to **Round**.

A cylinder named **Round** is drawn.

2. Intersect the coil and the new cylinder:

- a. In the history tree, select **Coil1**, press and hold down the **Ctrl** key, and then select **Round**.
- b. Click **Modeler > Boolean > Intersect**.

The intersected object is named **Coil1**.

## Move the Coil into the Final Position

To move the coil into its final position.

1. Select **Coil1** in the history tree window.
2. Select **Edit > Arrange > Move**.
3. Type **(0, 0, 0)** in the **(X, Y, Z)** fields, for the origin of the new location, and then press **Enter**.
4. Type **(0, 54.5, 0)** in the **(dX, dY, dZ)** fields, as the target point of new dimensions, and press **Enter**.

## Create a Mirror Duplicate of the Coil

To create a second coil by mirroring the first:

1. Select **Coil1** in the history tree window.
2. Select **Edit > Duplicate > Mirror**.

3. Type **(0, 0, 0)** in the **(X, Y, Z)** fields as the coordinates of the anchor point on the mirror plane, and then press **Enter**.
4. Type **(0, 1, 0)** in the **(dX, dY, dZ)** fields as coordinates of the target point of the vector normal to the mirror plane, and press **Enter**.

A second coil is created and named **Coil1\_1**. The geometry should appear as shown below:

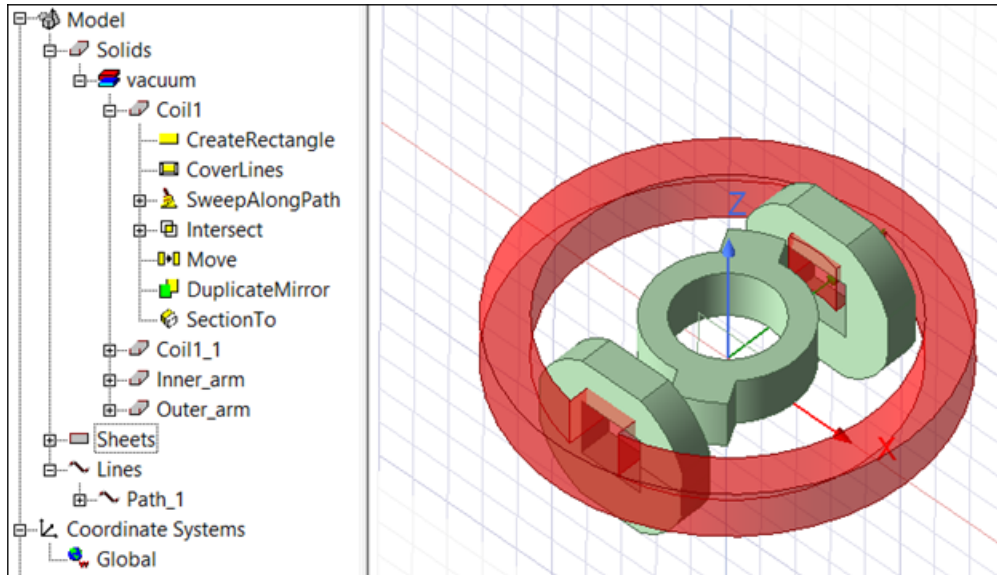

## Create the Coil Terminals

To create the terminals for the coils:

1. In the history tree, select **Coil1**, press and hold down the **Ctrl** key, and select **Coil1\_1**.
2. Click **Modeler > Surface > Section**.
3. Select **XY** as the **Section Plane**.
4. Click **OK**.
5. Click **Modeler > Boolean > Separate Bodies**. This separates the interlinked sheet objects created when the intersection of the XY plane created two terminals in each coil. The resulting four objects are automatically named:
  - **Coil1\_Section1**
  - **Coil1\_Section1\_Separate1**
  - **Coil1\_1\_Section1**
  - **Coil1\_1\_Section1\_Separate1**
6. Delete the two redundant terminals:
  - a. In the history tree, select **Coil1\_Section1\_Separate1**, press and hold down the **Ctrl** key, and select **Coil1\_1\_Section1\_Separate1**.

- b. Press **Delete**.
7. Select **Coil1\_Section1** in the **Sheets** section of the history tree.
8. Change the name of **Coil1\_Section1** to **Section1** and press **Enter**.
9. Select **Coil1\_1\_Section1**, and change its name to **Section2**.

## Create the Background (Region)

Define a background region box with the origin at (-250, -250, -250) and the dimensions of (500, 500, 500).

To create the background region box:

1. Click **Draw > Box**.
2. Type the box position (**-250, -250, -250**) in the **X**, **Y**, and **Z** fields at the bottom of the screen, and then press **Enter**.
3. Type the box size (**500, 500, 500**) in the **dX**, **dY**, **dZ** fields, and then press **Enter**.
4. In the Properties window's **Attribute** tab, change the **Name** (currently **Box3**) to **Bgnd**.
5. Set the transparency to **0.9**:
  - a. Click the button for the **Transparent** property.  
The **Set Transparency** dialog box appears.
  - b. Type **0.9** in the text box, and click **OK** to return to the **Properties** window.

A box named **Bgnd** is drawn.

**Note:** Alternatively, the **Draw > Region** command may be used to create the background object.

6. Press **Ctrl-D** to fit the drawing in the window.

The final geometry should look similar to the following:

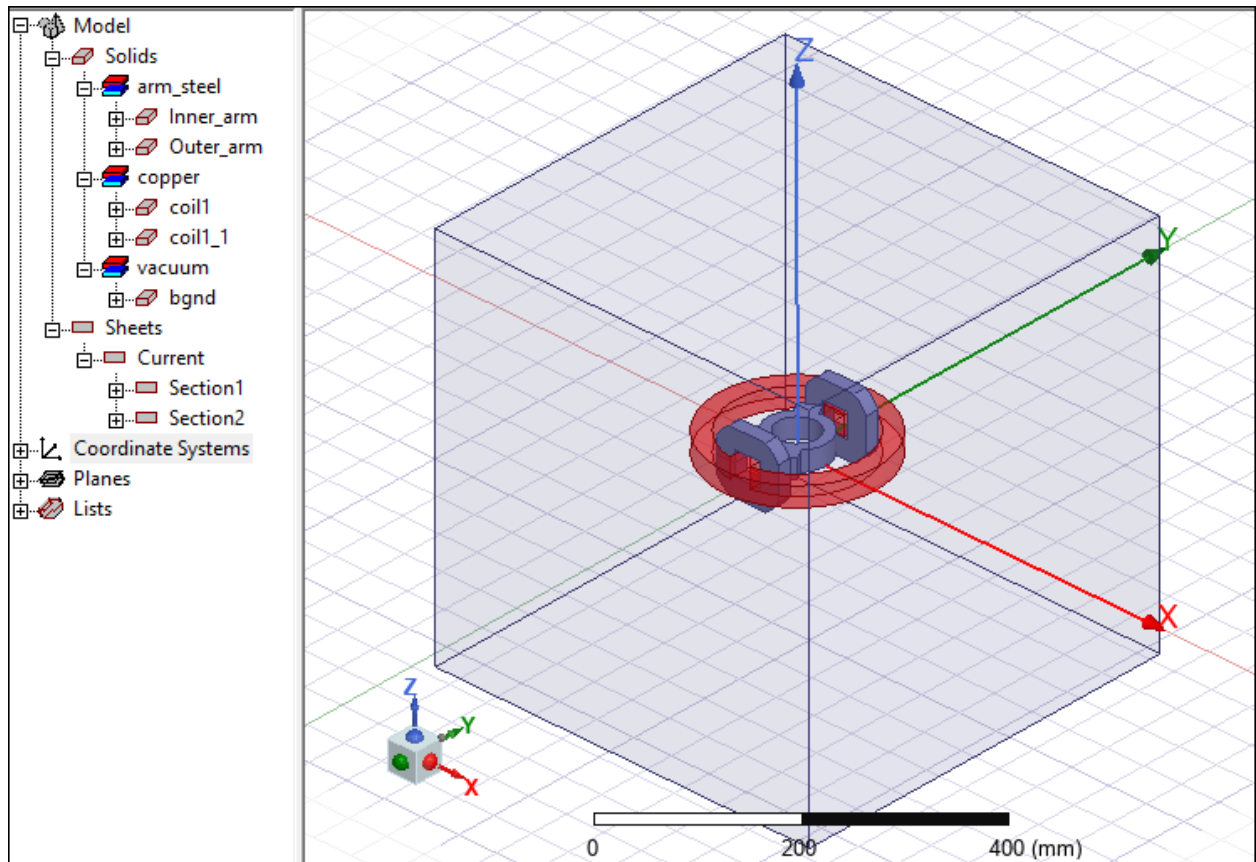

## Parameterize the Model

To finalize the geometry:

1. Select the **Inner\_arm** object in the history tree.
2. Click **Edit > Arrange > Rotate**.  
The **Rotate** dialog box appears.
3. Select the **Z** radio button for the **Axis**.
4. Thinking ahead, we will want to evaluate the device over a range of armature angles. Therefore, enter "**Angle**" into the value field and click **OK**.

The **Add Variable** dialog appears as shown to specify the value for the variable.

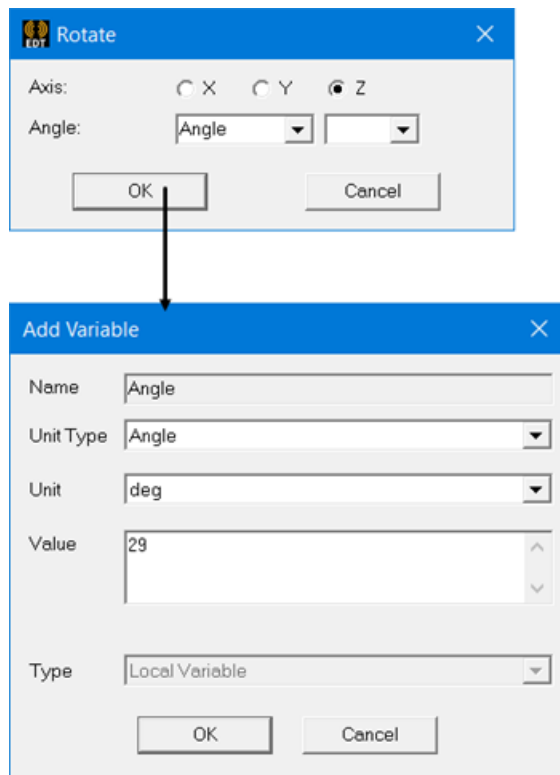

5. Ensure that the Unit Type is set to Angle, and the Unit is set to deg. Type **29** in the **Value** text box.
6. Click **OK**.

**Note:** Most numeric entry fields allow entry of a variable name for use in parametric or optimization.

7. Click **File > Save** to save the final version of the model before moving on to defining materials.

## 4 - Defining Material Properties

Default material properties are automatically assigned when you create the geometry objects. You can view these properties by viewing the **Attribute** tab of the **Properties** window. The default material for all objects is **vacuum**, which can be changed as soon as you draw an object. For this example, you will set the material definitions for all objects at the same time after the entire geometry has been created.

In this chapter you will complete the following tasks:

- [Assign nonlinear material to armatures](#)
- [Assign steel material to other objects](#)

### Define the Nonlinear Material for Armatures

To define the nonlinear material for the armatures:

1. Double-click the **Outer\_arm** object in the history tree.  
The **Properties** window appears.
2. Go to the Properties window.
3. In the **Material** row, click the value in the **Value** column.  
A drop-down list appears.
4. Select the **Edit...** item in the list.  
The **Select Definition** dialog box appears.
5. On the **Materials** tab, click the **Add Material** button.  
The **View / Edit Material** dialog box appears.
6. Type **arm\_steel** in the **Material Name** box.
7. Do the following in the **Properties of the Material** section:
  - a. In the **Type** column of the **Relative Permeability** row, select **Nonlinear** from the drop-down list.
  - b. In the **Value** column of the **Relative Permeability** row, click the **BH Curve** button.  
The **BH Curve** dialog box appears. By default, 10 rows are available to enter data points, but this example requires 20.
  - c. In the **Coordinates** section, append 10 additional rows to the table to reach a total of 20 data rows:
    - i. Click the **Append Rows** button.
    - ii. Type **10** in the **Number of rows** text box, and click **OK**.

The **BH Curve** dialog box reappears, with 20 rows now available in the table.

- d. Type the following **H** and **B** data in the **Coordinates** section:

**Note:** When entering data into the Coordinates section, the **Tab** key can be used to sequentially move to the next entry position.

	<b>H (A/m)</b>	<b>B (T)</b>
<b>1.</b>	0	0
<b>2.</b>	4000	1.413
<b>3.</b>	8010	1.594
<b>4.</b>	16010	1.751
<b>5.</b>	24020	1.839
<b>6.</b>	32030	1.896
<b>7.</b>	40030	1.936
<b>8.</b>	48040	1.967
<b>9.</b>	64050	2.008
<b>10.</b>	80070	2.042
<b>11.</b>	96080	2.073
<b>12.</b>	112100	2.101
<b>13.</b>	128110	2.127
<b>14.</b>	144120	2.151
<b>15.</b>	176150	2.197
<b>16.</b>	208180	2.24
<b>17.</b>	272230	2.325
<b>18.</b>	304260	2.37
<b>19.</b>	336290	2.42
<b>20.</b>	396000	2.5

The curve should appear as shown below:

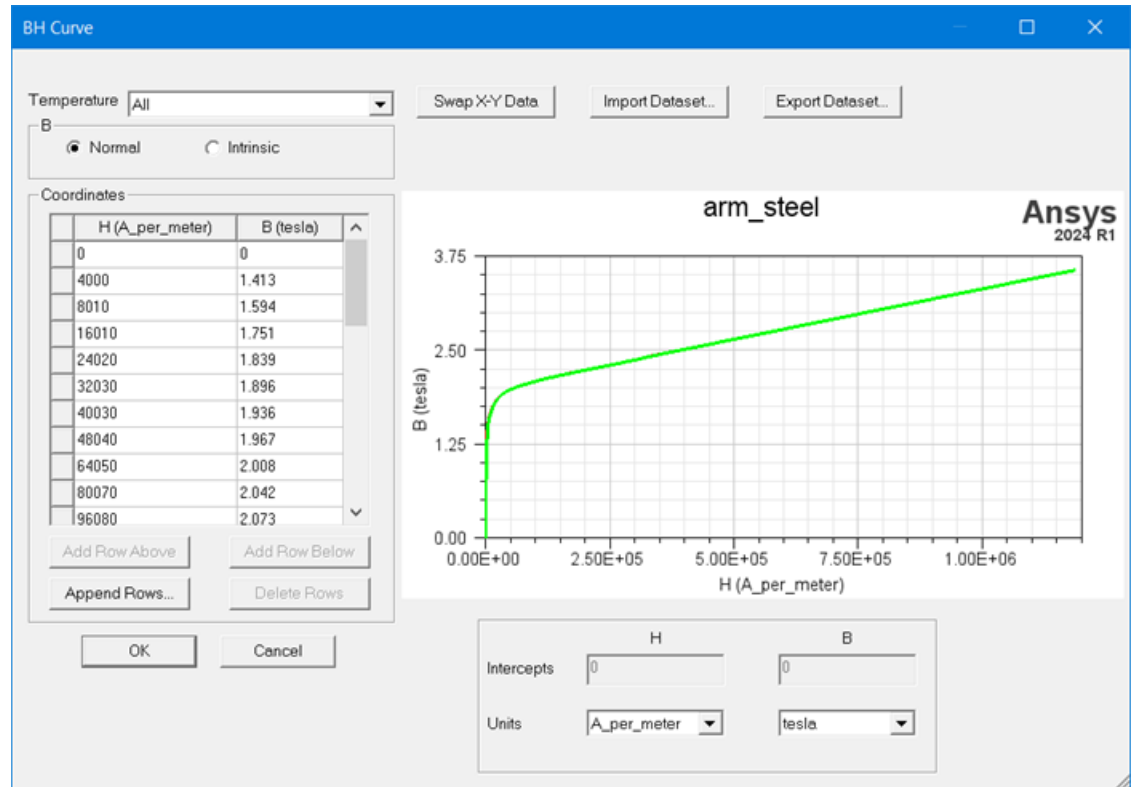

e. Click **OK**.

The **BH Curve** dialog box closes, and the **View / Edit Material** dialog box reappears.

f. In the **Value** column of the **Bulk Conductivity** row, enter **2e6**.

g. In the bottom right of the **View / Edit Material** dialog box, click **Validate Material**.

A green check mark appears if the material is valid.

8. Click **OK** to close the **View / Edit Material** dialog box.

The **Select Definition** dialog box reappears.

9. Click **OK** to close the **Select Definition** dialog box.

## Assign Material Properties for Other Objects

Select the **Inner\_arm** object, and assign the newly defined **arm\_steel** property. Select the two coils, and assign **copper** as the material property:

To assign the material properties to the model objects:

1. Select the **Inner\_arm** object in the history tree.
2. In the Properties window's **Material** row, click the field in the **Value** column.  
A drop-down list of available materials appears.
3. Select **arm\_steel** from the list of materials.
4. Repeat steps 1 through 3 to assign **copper** to **Coil1**.
5. Repeat steps 1 through 3 to assign **copper** to **Coil1\_1**.
6. Leave the material assignment for the **Bgnd** object unchanged.

## 5 - Setting Up and Running the Analysis

In this chapter you will complete the following tasks:

- Set up excitations and calculations
- Set up the analysis
- Run and solve the analysis

### Assign Excitations

Currents need to be defined and assigned as excitations for the two coil terminals.

To define the currents:

1. Select **Section1** and **Section2** in the history tree.
2. Click **Maxwell 3D > Excitations > Assign > Current** from the menu.

The **Current Excitation** dialog box appears.

**Note:** Excitations may also be assigned using the shortcut menu. Right-click on **Excitations** in the Project Manager tree. In the Shortcut menu, select **Assign > Current**.

3. Type **675.5** in the **Value** text box, and select **A** as the units.
4. Select **Stranded** as the **Type**.
5. Click **OK**.

By default, all faces of the region box (**Bgnd**) are assigned with magnetic flux tangent boundary conditions. Therefore, no additional boundary conditions are required for this example problem.

### Set Up Parameter Calculations

In this example, you will calculate the [torque](#) and [inductance](#) matrix parameters.

#### Set Up the Torque Calculation

To set up the torque calculation:

1. Select the **Inner\_arm** object by clicking its name in the history tree.
2. In the Project Manager tree, expand the model until you see the **Parameters** entry.
3. Right-click **Parameters** and select **Assign > Torque** from the shortcut menu.

The **Torque** dialog box appears.

4. Leave the **Type** set to **Virtual**.
5. Select **Global:Z** from the **Axis** drop-down list.
6. Select the **Positive** radio button for the axis orientation.
7. Click **OK**.

## Set Up the Inductance Matrix Calculation

To set up the inductance matrix calculation:

1. Right-click the **Parameters** entry in the Project Manager tree, and select **Assign > Matrix** from the shortcut menu.

The **Matrix** dialog box appears.

2. Click the **Setup** tab.
3. Select **Include** for both **Coil1** and **Coil1\_1** for the inductance calculations to be performed. The self inductances and mutual inductances will be calculated.
4. Click **OK**.

## Exploring the Matrix Setup Grouping Functionality

The matrix setup provides a grouping functionality on the **Post Processing** tab:

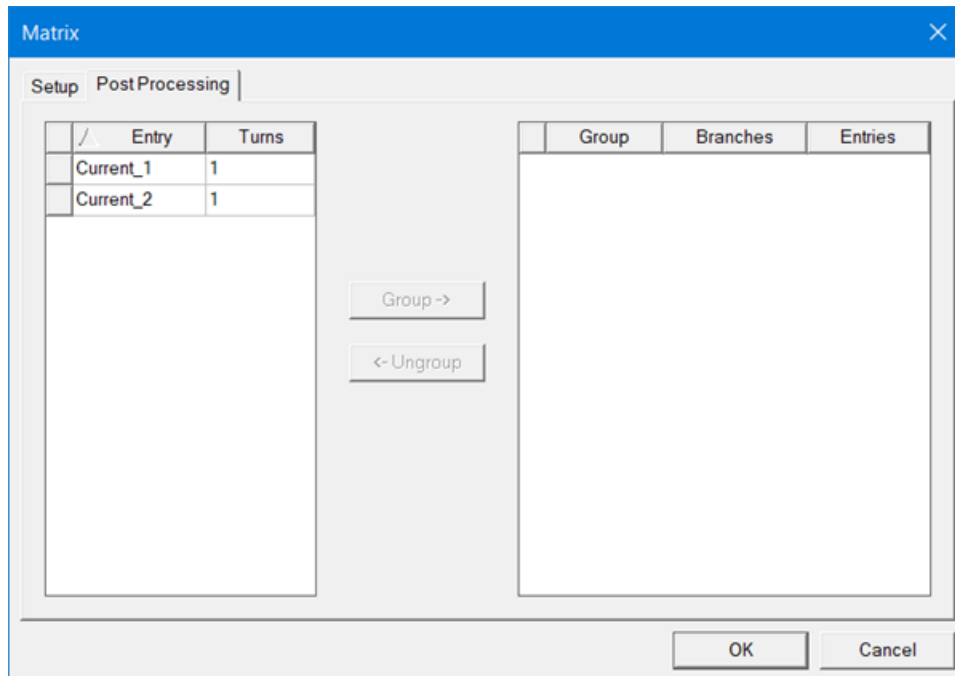

Thus, in addition to inductance matrix entries calculation, Maxwell can perform a grouping calculation.

To perform a grouping calculation:

1. Select the matrix entry and specify the corresponding number of turns.
2. Select all matrix entries to be involved in grouping and click the **Group** button.
3. Specify the number of branches.

The operations performed by the grouping function can be one of the following three cases:

- Series connection if the number of branches is set to 1.
- Parallel connection if number of branches is equal with the total number of coils (matrix entries).
- Series/parallel if the number of branches is different from the two above.

### Example 1: Series/Parallel

Assume a situation with 4 coils, each with 18 turns, all 4 selected to be grouped with the number of branches set to 2. In this case, 9 turns from each of the 4 coils ( $18 / 2$  branches = 9) are connected in series and paralleled, with the other 9 turns of the same coils also connected in series.

### Example 2: Series/Parallel

Assume a situation with 5 coils, each with 15 turns and number of branches set to 3. In this case, the equivalent S/P corresponds to taking the first 5 turns from each of the 5 coils and connecting them in series, taking the next 5 turns from the same coils and connecting them in series, taking the final 5 turns from the coils and connecting them in series, and then finally connecting the emerging 3 subgroups in parallel.

**Note:** For the grouping in the S/P case to correspond to a physical situation, the number of turns must be an integer multiple of the number of branches.

## Set Up the Analysis

To set up the analysis:

1. Right-click the **Analysis** entry in the Project Manager tree, and select **Add Solution Setup**.  
The **Solve Setup** dialog box appears.
2. Click the **General** tab.
3. Accept the default values (**Maximum number of passes = 10** and **Percent Error = 1**).

These settings instruct the solver to solve up to 10 passes as the automatic adaptive

mesh refinement refines the mesh and improves the accuracy of the solution at run time.

4. Click **OK**.

## Validate Design

Before running a simulation, it is best to validate its setup.

1. From the **Maxwell 3D** menu, select **Validate Check**. Alternatively, from the **Simulation**



tab, you can click the **Validate** icon.

The **Validate Check** tool runs, and after it is complete, the Validate Check window appears:

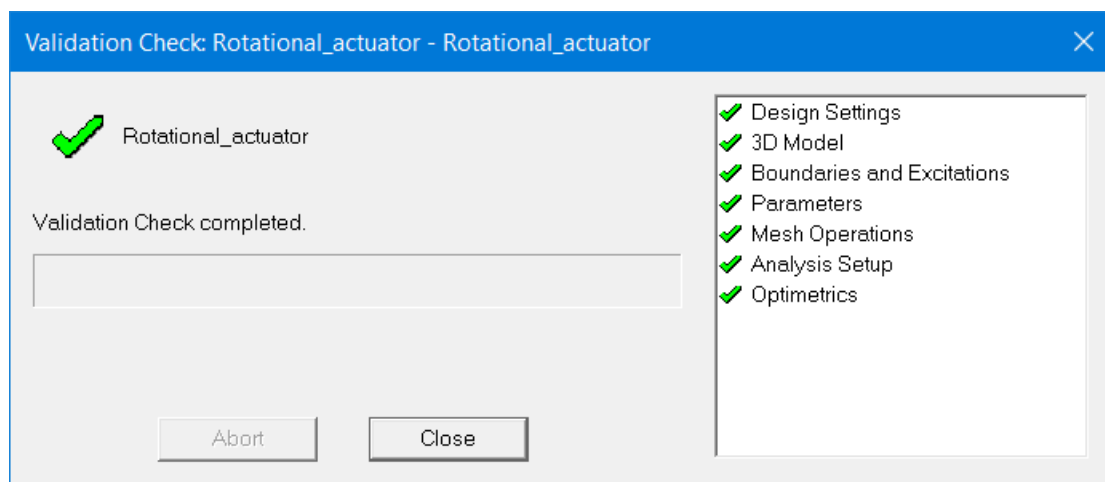

For this model, we see that the model, the design settings, and the simulation parameters were checked and validated. If the tool finds any problem with your design, it will be reported in this window. Make sure to address any of these issues before you run your simulation.

## Run the Analysis

To run the analysis:

1. Right-click the **Analysis** entry in the Project Manager tree, and select **Analyze**.
2. To visualize the progress of the solution:
  - a. Right-click the **Setup1** field (located under the **Analysis** field), and select **Convergence**.
  - b. Make sure the **Convergence** tab is selected.
  - c. Select a tabular or graphical format for how to visualize the information about the

energy, number of finite elements, torque, etc.

- d. Click **OK**.
3. When the solution is complete (it should take between 3 and 5 minutes on most PCs), look at the value of the torque from **LastAdaptive**.

The value should be about -0.19835 N m.

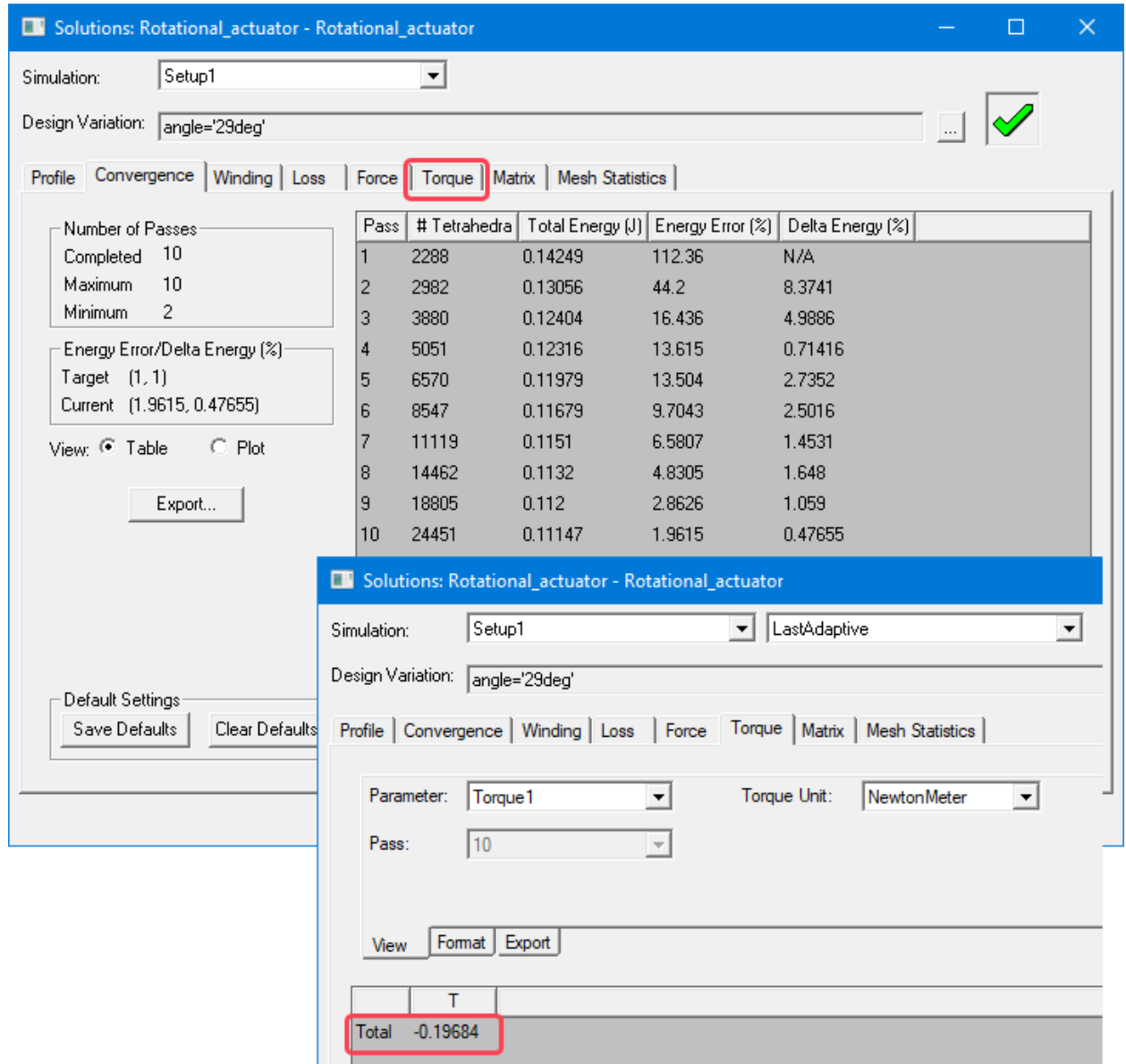



## 6 - Postprocessing the Results

In this chapter you will complete the following tasks:

- Plot the magnetic flux density vector
- Plot the magnetic flux density magnitude

### Plot the Magnetic Flux Density Vector

Plot the flux density vector on the mid-vertical symmetry plane of the device. You previously set up a relative coordinate system (RelativeCS1) containing the desired plot plane.

### Create an Object List

The plot results for the two armatures are of interest, so you will create a list of these two objects to plot only those results.

To create the list of objects:

1. Select the **Outer\_arm** and **Inner\_arm** objects.
2. Click **Modeler > List > Create > Object List**.

**ObjectList1** is created under the **Lists** section of the history tree.

### Plot the Quantity

To create the plot:

1. Change the rendering of objects in the model to wireframe by clicking **View > Render > Wire Frame**.
2. In the history tree, expand the **Planes** entry and select the **RelativeCS1:XY** plane. This will be the plane to create plots on.
3. In the Project Manager tree, right-click **Field Overlays**, and select **Fields > B > B\_Vector**. The **Create Field Plot** dialog box appears.
4. Make sure **B\_Vector** is selected in the **Quantity** list.
5. Select **Objectlist1** in the **In Volume** list.
6. Click **Done**.
7. Click **Maxwell 3D > Fields > Modify Plot Attributes**.

The **Select Plot Folder** dialog box appears.

8. Click the **Plots** tab.
9. Under the **Vector Plot** parameters, enter 4 in the **min** box.
10. Click **Apply**, and then click **Close**.

The plot should look similar to the following figure:

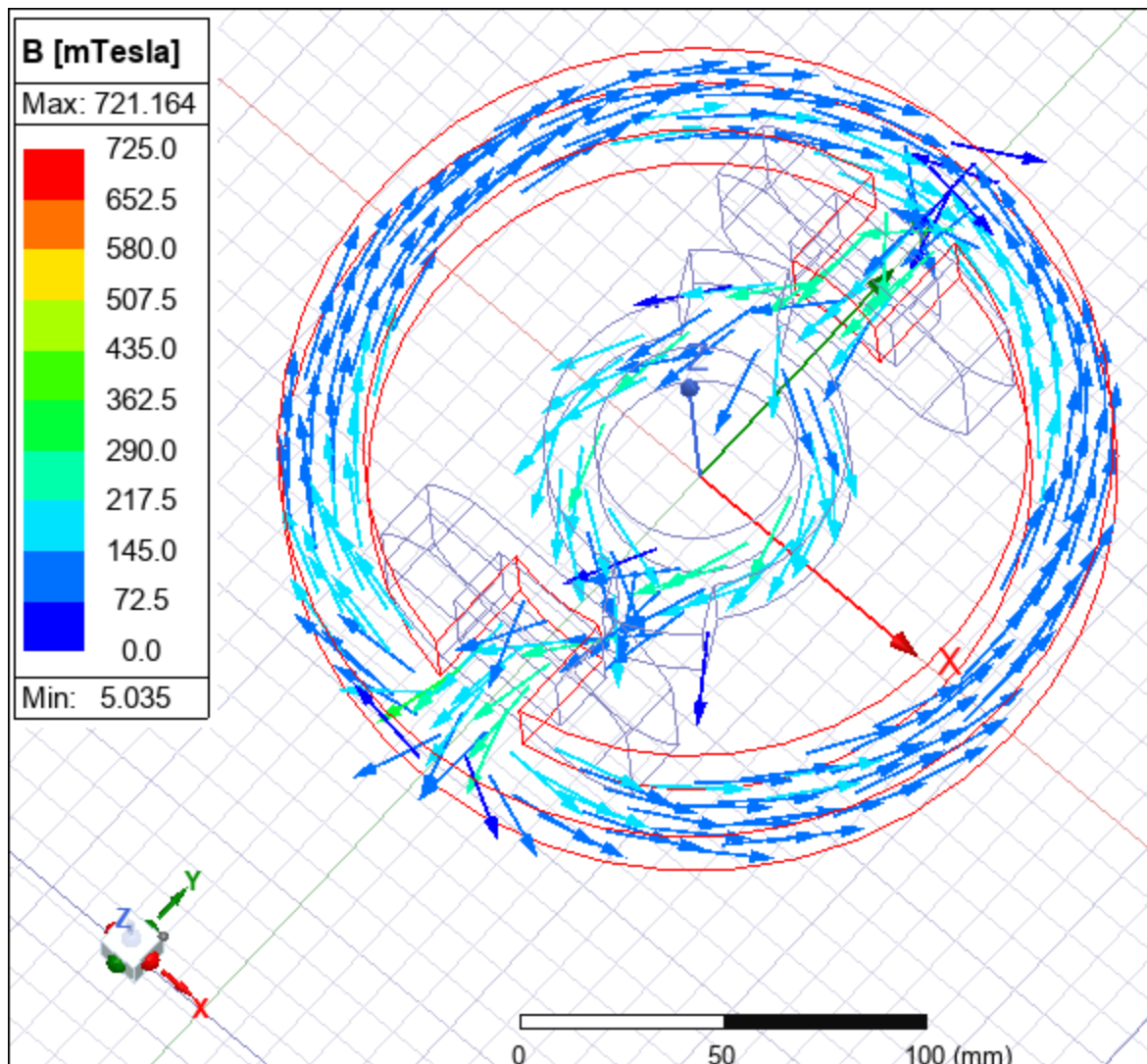

## Plot the Magnetic Flux Density Magnitude

To avoid overlapping with the previous plot, right-click the name of the previous plot (**B\_Vector**) under **Field Overlays**, and uncheck the **Plot Visibility** box.

1. Follow the procedure used to create the previous plot to plot the magnetic flux density magnitude (**B\_Mag**) on the same XY plane of the RelativeCS1 coordinate system.
2. In the Project Manager tree, expand **Field Overlays**, and then the **B** entry.
3. Double-click **Mag\_B1** to plot the B Magnitude results.
4. Once the plot is displayed, right-click in the color key and select **Modify**.

5. In the **Scale** tab, set the **Number of divisions** to **250** to get a smooth plot.
6. Click **Close**.

The plot should look similar to the following figure:

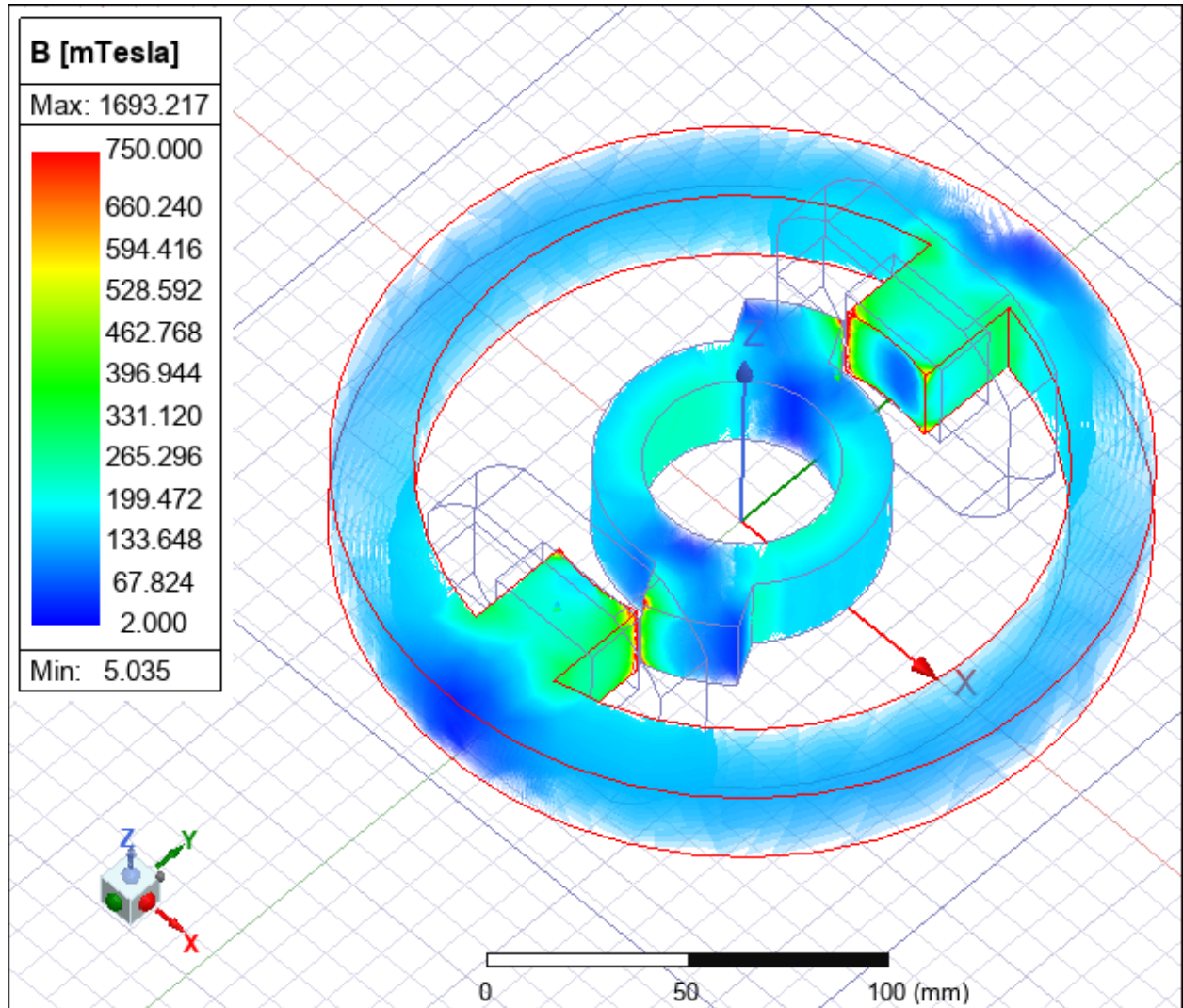



## 7 - Running a Parametric Analysis

In this chapter you will complete the following tasks:

- Run a parametric analysis
- Create an analysis report
- Close the project and exit Maxwell

### Parameterization and Parametric Analysis

Parameters can be easily added to the setup for the purpose of changing assigned values (making "what if" type of analysis easy to perform), which in turn, makes it easier to set up and run a parametric analysis. The quantities that can be parameterized include geometric attributes, material properties, excitations, etc.

In this application, we define the rotation angle of the **Inner\_arm** object as a parameter and then perform a parametric analysis aimed at obtaining the self and mutual inductance of the two coils as well as the torque for a whole range of rotation angles. The rotation angle was specified as a variable during the creation of the geometric model.

To define the angle variable as a design parameter:

1. In the Project Manager tree, right-click the **Optimetrics** entry and select **Add > Parametric**.
2. In the **Setup Sweep Analysis** dialog, click **Add** to add a variable to the sweep.
3. Select the variable **Angle** from the drop-down list.
4. Select **Linear Step** as the type of sweep.
5. Enter **0 deg** for the **Start** value, **30 deg** for the **Stop** value, and **5 deg** for the **Step** value.
6. Click the **Add** button, and then **OK**.
7. Select the **Calculations** tab.
8. Click the **Setup Calculations** button.
9. In the **Add/Edit Calculation window**, select **Magnetostatic** for **Report Type**, **Setup1: LastAdaptive** for **Solution**, and **None** for **Parameter**.
10. From the Trace tab, under **Category**, select the following variables:
  - a. Select **Torque > Torque1.Torque** and click **Add Calculation**.
  - b. Select **L > Matrix1.L(Current\_1, Current\_1)** and click **Add Calculation**.
  - c. Select **L > Matrix1.L(Current\_1, Current\_2)** and click **Add Calculation**.
  - d. Select **L > Matrix1.L(Current\_2, Current\_2)** and click **Add Calculation**.
11. Click **Done**.

Setup Sweep Analysis	
Sweep Definitions   Table   General   Calculations   Options	
Solution	Calculation
Setup1 : LastAdaptive	Torque1.Torque
Setup1 : LastAdaptive	Matrix1.L(Current_1,Current_1)
Setup1 : LastAdaptive	Matrix1.L(Current_1,Current_2)
Setup1 : LastAdaptive	Matrix1.L(Current_2,Current_2)

12. Back in the **Setup Sweep Analysis** window, select the **Options** tab.
13. Select the **Save Fields And Mesh** check box.
14. Click **OK** when complete.

A **ParametricSetupn** entry is now shown under Optimetrics in the project tree.

To start the parametric analysis:

1. Right-click the **ParametricSetup1** entry in the Project Manager tree, and select **Analyze**.

**Note:** Because you are solving multiple geometric problems, the solution time required will be proportionately longer than solving the non-parametric solution in the previous chapter.

## Create a Parametric Analysis Report

Once the parametric analysis is complete, create analysis report:

To create a report:

1. In the Project Manager tree, right-click the **Results** entry and select **Create Magnetostatic Report > Rectangular Plot**.
2. In the **New Report** window set the **Solution** to **Setup1:LastAdaptive** and **Parameter** to **None**.
3. Under **Category** select **L** and hold down the **Ctrl** key and select **Matrix1.L(Current\_1,Current\_1)**, **Matrix1.L(Current\_1,Current\_2)**, **Matrix1.L(Current\_2,Current\_1)**, and **Matrix1.L(Current\_2,Current\_2)**, then click **New Report**.
4. Click **Close** when finished.

The plot should look similar to the following figure.

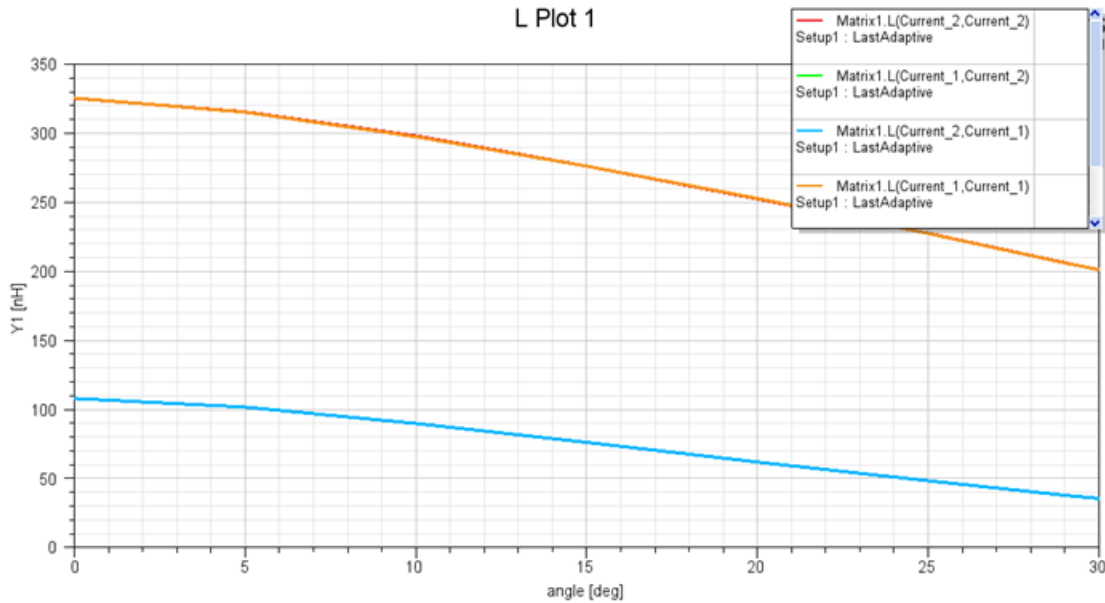

The L11 and L22 traces overlap. This is normal because the respective inductances should be identical.

## Create an Animation Using Saved Parametric Field Data

You can perform an animation using the saved data.

To perform an animation:

1. In the Project Manager tree, under **Field Overlays**, select the desired field plot that is to be animated (such as the **B vector** field plot created in chapter 6).
2. Right-click the plot, and select **Animate**.

The **Setup Animation** dialog box appears.

3. If only one variable is available, click **Animate**.
4. If more than one variable is available, click the **Swept Variable** tab.
5. Select the desired variable from the **Swept variable** drop-down menu (**angle** in this case).
6. Select the desired variations from the **Select values** section.
7. Click **OK** to start the animation process.  
The **Animation** play panel appears, allowing you to pause and otherwise control the animation.
8. Click **Close** to stop the animation display.

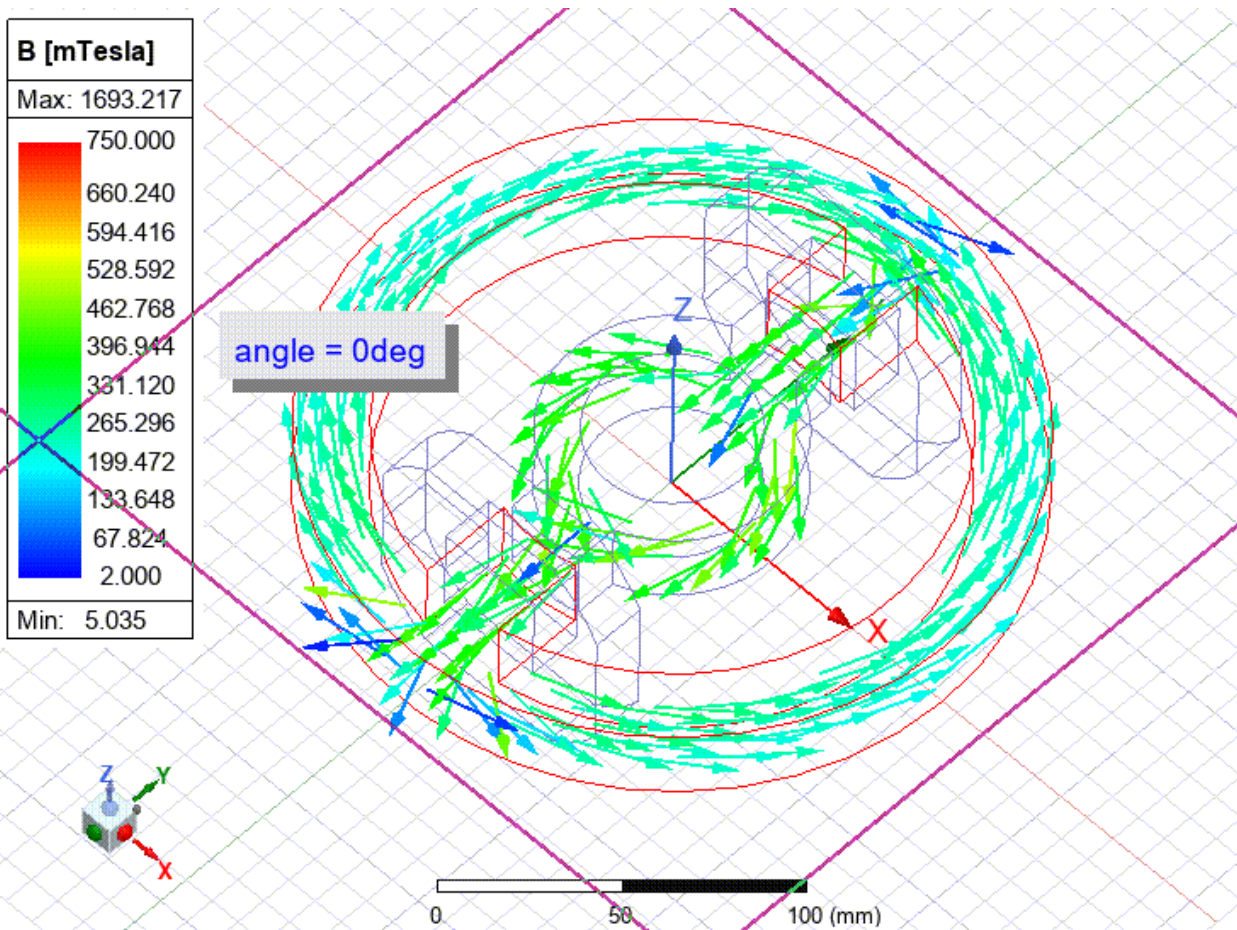

**Note:** You can export the animation as an animated **.gif** or **.avi** file by clicking **Export** in the **Animation** play panel.

**Note:** Maxwell can take advantage of computing resources on various computers that can be accessed on a local network. Using the **High Performance Computing (HPC)** feature, you can solve parametric designs in parallel (simultaneously) on multiple user-selected computers available on the local network. Please contact your account manager for details.

# 8 - Close the Project and Exit Electronics Desktop

Congratulations! You have successfully completed *Getting Started with Maxwell: Designing a Rotational Actuator*. You may close the project and exit the Ansys Electronics Desktop software.

1. Click **File** > **Save** to save the project.
2. Click **File** > **Close**.
3. Click **File** > **Exit** to exit Electronics Desktop.



# Index

## 3

3D Modeler window 1-2  
3D movement mode 3-1

## A

adding a solution setup 5-1  
adding parameters to a setup 7-1  
analysis setup 5-1  
Analyze command 5-1  
analyzing the solution 5-1  
animation 7-3  
assigning excitations 4-3  
attributes, plot properties 6-1, 6-2

## B

B vector 6-1, 6-2  
background region 3-18  
BH-curve 4-1  
Boolean operations 3-17  
box object 3-5

## C

closing Maxwell 7-2

closing the project 7-2  
coil cross-section 3-14  
coil terminal 5-1  
coil terminals 3-17  
creating a coordinate system 3-13  
creating a parametric analysis report 7-2  
creating a path 3-14  
creating an animation 7-2  
creating an inner armature object 3-6  
creating an object list 6-1  
creating outer armature object 3-1  
creating the background region 3-18  
creating the coil terminals 3-17  
cross-section of a coil 3-14  
currents 5-1  
cylinder object, drawing 3-2

## D

defining material properties 4-1  
defining the background region 3-18  
desktop 1-2  
    fit all 3-4  
diagram of example design 1-2

distributed processing 7-2

drawing a box 3-5

drawing a cylinder 3-2

drawing a rectangle 3-14

drawing plane 3-1

drawing units 2-2

duplicating an object 3-6

## E

electric 3D field solutions 1-1

excitations 5-1

exiting Maxwell 7-2

## F

field overlays 6-1

fit all in modeler window 3-3

## G

general design procedure 1-2

## H

harmonic steady-state solutions 1-1

history tree 1-2

## I

inner armature 3-8

intersecting objects 3-16

## M

magnetic flux density vector 6-1

magnetostatic solution type 2-1

magnetostatic solutions 1-1

material properties 4-1

## Maxwell

closing 7-2

exiting 7-2, 7-2

renaming a design 2-1

renaming a project 2-1

saving a project 7-2

Maxwell desktop 1-2

Maxwell solution types 1-1

menu bar 1-2

Message window 1-2

mirroring an object 3-6

modifying plot attributes 6-1, 6-2

Movement mode 3D 3-1

moving objects 3-5

## N

nonlinear material 4-1

## O

object list, creating 6-1

opening a project 2-1

outer armature 3-1

## P

parameterization 7-1

parameters 7-1  
parametric analysis 7-1  
parametric analysis report 7-2  
parametric sweep 7-1  
performing an animation using  
    saved data 7-2  
plot attributes 6-1  
plotting  
    magnetic flux density vector 6-1  
    object list 6-1  
    preparation 6-1  
post processing 6-1  
preparing for a plot 6-1  
Progress window 1-2  
Project Manager window 1-2  
project tree 1-2  
project, closing 7-2  
projects, opening and saving 2-1  
properties, plot attributes 6-1, 6-2

## Q

quantity, plotting 6-1, 6-2

## R

rectangle, drawing 3-14  
renaming  
    a design 2-1  
    a project 2-1

report, parametric analysis 7-2  
rotating an object 3-19  
rotational actuator example 1-2

## S

saving a project 2-1  
saving Maxwell project 7-2  
separate bodies 3-17  
setting drawing units 2-2  
setting the drawing plane 3-1  
setting the movement mode 3-1  
setting up Maxwell designs 1-3  
setting up the analysis 5-1  
simulation 5-1  
sinusoidal solutions 1-1  
solution setup 5-3  
solution simulation 5-1  
solution type 1-1  
sources 4-3  
subtracting objects 3-4  
sweeping a cross-section 3-14  
sweeping variables 7-1

## T

TEAM workshop problem 24 1-2  
time domain solution 1-1  
toolbars 1-2  
transient electric fields 1-1

transient solutions 1-1

**U**

uniting objects 3-6

**V**

viewing entire screen 3-3

**W**

windows in Maxwell desktop 1-2

**X**

XY drawing plane 3-1